

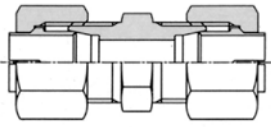

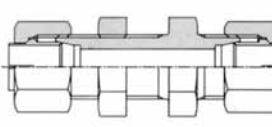
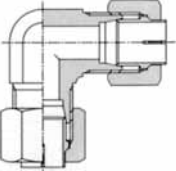
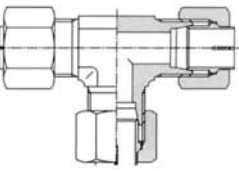
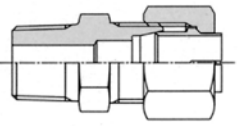
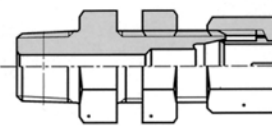
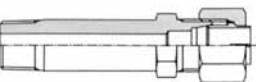
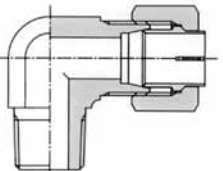
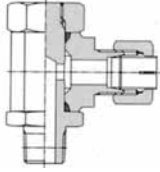
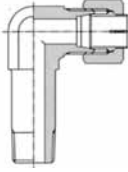
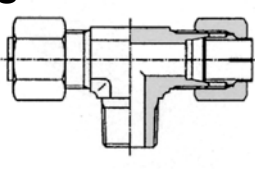
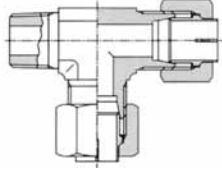
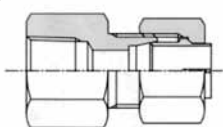
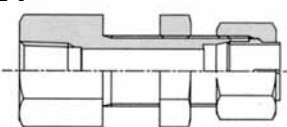
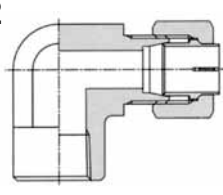
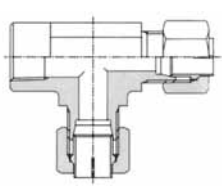
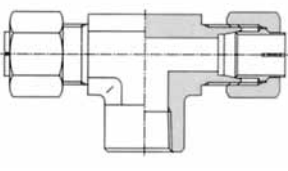
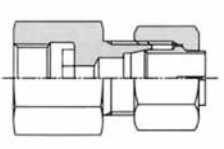
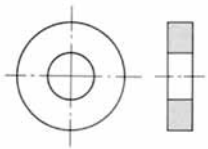
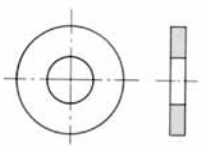
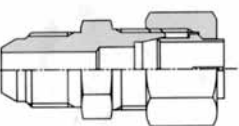
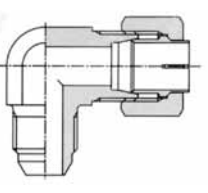
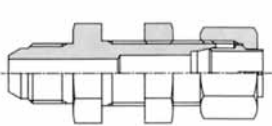
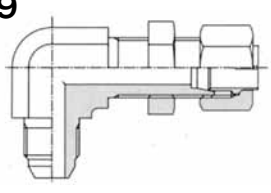
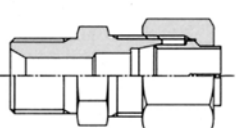
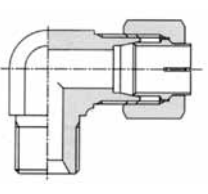
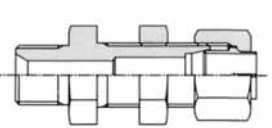
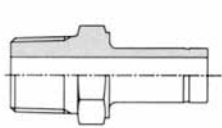
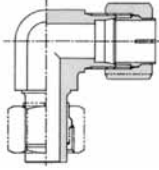
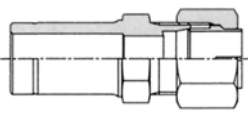
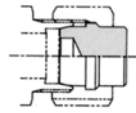
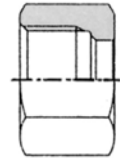
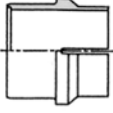
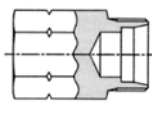
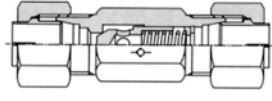
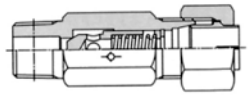
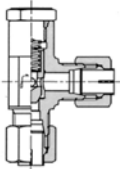

CE Series Bite Type Fittings for Steel Tube VISUAL INDEX

<p><b>Union KUA</b></p> <p><b>10</b></p> 	<p><b>Bulkhead Union KSU</b></p> <p><b>10</b></p> 	<p><b>Union Elbow KLA</b></p> <p><b>11</b></p> 	<p><b>Union Tee KTA</b></p> <p><b>11</b></p> 
<p><b>Male Connector KCT</b></p> <p><b>12</b></p> 	<p><b>Bulkhead Male Connector KSC</b></p> <p><b>13</b></p> 	<p><b>Extended Male Connector KAA</b></p> <p><b>14</b></p> 	<p><b>Male Elbow KLN</b></p> <p><b>15</b></p> 
<p><b>Stud Elbow (Type-C) KMC</b></p> <p><b>16</b></p> 	<p><b>Extended Male Elbow KLL</b></p> <p><b>17</b></p> 	<p><b>Male Branch Tee KTN</b></p> <p><b>18</b></p> 	<p><b>Male Run Tee KTK</b></p> <p><b>19</b></p> 
<p><b>Female Connector KSA</b></p> <p><b>20</b></p> 	<p><b>Bulkhead Female Connector KSS</b></p> <p><b>21</b></p> 	<p><b>Female Elbow KLF</b></p> <p><b>22</b></p> 	<p><b>Female Run Tee KTF</b></p> <p><b>23</b></p> 
<p><b>Female Branch Tee KTH</b></p> <p><b>24</b></p> 	<p><b>Connector for Pressure Gauge KGA</b></p> <p><b>25</b></p> 	<p><b>Gasket KP-B</b></p> <p><b>25</b></p> 	<p><b>Gasket KP-D</b></p> <p><b>25</b></p> 
<p><b>Male Seat Hose Connection Union KUC</b></p> <p><b>26</b></p> 	<p><b>Male Seat Hose Connection Union Elbow KLD</b></p> <p><b>27</b></p> 	<p><b>Male Seat Hose Connection Bulkhead Union KUE</b></p> <p><b>28</b></p> 	<p><b>Male Seat Hose Connection Bulkhead Union Elbow KLH</b></p> <p><b>29</b></p> 
<p><b>Female Seat Hose Connection Union KUD</b></p> <p><b>30</b></p> 	<p><b>Female Seat Hose Connection Union Elbow KLE</b></p> <p><b>31</b></p> 	<p><b>Female Seat Hose Connection Bulkhead Union KUF</b></p> <p><b>32</b></p> 	<p><b>Adapter KHA</b></p> <p><b>33</b></p> 

<p><b>Adjustable Elbow KLC</b></p> <p><b>34</b></p> 	<p><b>Reducer KRE</b></p> <p><b>35</b></p> 	<p><b>Plug KBA</b></p> <p><b>36</b></p> 	<p><b>Nut KKN</b></p> <p><b>36</b></p> 
<p><b>Sleeve KKO</b></p> <p><b>36</b></p> 	<p><b>Presetting PJA</b></p> <p><b>36</b></p> 	<p><b>Union KZU</b></p> <p><b>37</b></p> 	<p><b>Check Connector KZC</b></p> <p><b>38</b></p> 
<p><b>Check Elbow KZL</b></p> <p><b>39</b></p> 			
<p><b>Pre-Setting Device for Bite Type Fittings</b></p>	<p><b>Pre-Setting Device PSD-S</b></p> <p><b>40</b></p> 	<p><b>Pre-Setting Device PSD-BCE</b></p> <p><b>40</b></p> 	<p><b>Tightening Equipment for Bite Type Fitting</b></p> <p><b>41</b></p> 

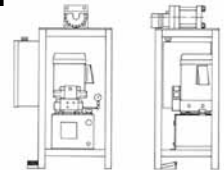
**EXPLANATION OF WARNINGS AND CAUTIONS IN THIS CATALOGUE**

- ⚠ **Warning** : When this sign is ignored and improperly used, there will be danger of accidents occurring that may result in physical injuries and/or death.
- ⚠ **Caution** : When this sign is ignored and improperly used, there will be possibility of the product not performing as specified.

CE Series Bite Type Tube Fittings have been developed as fittings for use in hydraulic applications with pressure up to 13.7 MPa (140 Kgf/cm<sup>2</sup>) such as machine tools. Being more compact in size than conventional fittings and possessing substantially improved vibration resistance and leak prevention, these fittings can be used not only for hydraulic equipment but also for lubrication piping and air piping. For applications where pressure above 13.7 MPa (140 Kgf/cm<sup>2</sup>) are required, the NE Series Bite Type Tube Fittings are available.

## 1. FEATURES OF CE SERIES BITE TYPE TUBE FITTINGS

- 1) CE Series Bite Type Tube Fittings do not require welding, threading nor flaring and piping man hour can be saved.
- 2) The envelope of the sleeve enables strict centering of the piping and contributes to substantially reduce the trouble of off-centering which has been the major cause for leakage in piping.
- 3) With the function of the envelope with slits which has been analyzed by finite element method, vibration fatigue resistance has been improved by more than 20% (company comparison).
- 4) Workability has been substantially enhanced by reducing the size to approximately 75% (volumetric comparison) and the tightening torque by 25 to 30% in comparison to the conventional type. This enables performing compact piping within restricted space.
- 5) Fittings are in accordance with Japan Machine Tool Industrial Society Standard (MAS 206-1991). JIS B 2351 is the popularly known standard applying to bite type fittings but MAS standard has adopted higher bending stress values for vibration resistance test than JIS standard taking into consideration the operating conditions of machine tools. The main dimensions of the fittings are established smaller dimensions.

## 2. FUNCTION OF THE CE SERIES BITE TYPE TUBE FITTINGS

The CE Series Bite Type Tube Fitting consists of the fitting body, nut and sleeve.

As the nut is tightened, the sleeve is forced forward in between the tapered surface of the fitting body and the tube, and completely seals the fluid.

As the sleeve is being swaged by the tapered surface of the fitting body, the cutting edge on the forward end of the sleeve bites into the tube and firmly grips the tube. The opposite end of the sleeve is deformed by the tapered surface of the nut and, by firmly holding the tube, relieves stress concentrating at the biting part caused by vibration. The bowing action of the sleeve works as a spring to prevent loosening of the nut.

The envelope at the rear edge of the sleeve spreads the stress generating on the tube at the rear edge on the tube and also improve vibration resistance strength of the tube.

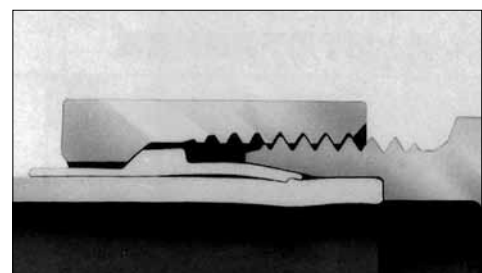
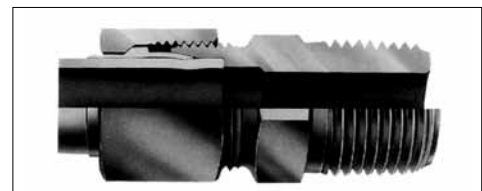

**⚠ Warning :** Intermix other vendors' parts (body, nut, sleeve) with CE fitting parts is strictly prohibited.

It might cause the serious accidents due to the degradation of the fitting performance.



## 7. Recommended Wall Thickness of Applicable Tubes

Wall thickness	Std dimension	1	1.2	1.5	2	2.5	3
	Allowance	±0.15	±0.15	±0.2	±0.2	±0.25	±0.3
Tube OD							
Std dimension	Allowance						
6	±0.10	○					
8		○					
10		○					
12			○				
16					○		
20						○	
25						○	
30	±0.15						○

### Remarks

1. Scope of recommended wall thickness is shown within .
2. ○ indicates recommended wall thickness when using CE Series Bite Type Tube Fittings at the rated pressure of 13.7 Mpa (140 Kgf/cm<sup>2</sup>). Calculation shall be in accordance with JIS B 2351-1969 and the calculation formula shall be as follows with the tube to be used being OST-2.

$$t = \frac{d_o P}{2 \sigma_{max}}$$

t : Wall thickness (mm)  
 d<sub>o</sub> : OD (mm)  
 σ<sub>max</sub> : Allowable stress (88.3 N/mm<sup>2</sup>)  
 P : Pressure (13.7 Mpa)

## 8. Sizes and Installation Dimensions

unit: mm

Applicable Tube OD A	I	D <sub>1</sub>	K	Width Across Hex. H
6	5.5	7.05	1.3	12
8	5.5	9.05	1.1	14
10	5.5	11.15	1.1	17
12	6.0	13.15	1.1	19
16	8.0	17.35	1.2	27
20	8.0	21.75	1.0	30
25	9.0	26.75	1.0	36
30	9.0	31.85	1.0	41

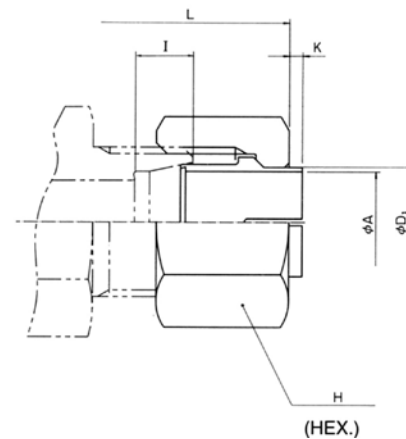

Note: For dimension of "L" refer to individual fittings in text.

## 9. TIGHTENING PROCEDURE

It is imperative that proper tubes are selected and the fittings are correctly tightened for the bite type fittings to fully exhibit its performance. Bite type fittings can be directly installed and tightened at the job site, but it is recommended to perform presetting as explained below to confirm the condition of the sleeve biting into the tube. Presetting device is available for performing presetting work both efficiently and correctly as well as to obtain a positive connection. Refer to pages 40~41.

### 1) Presetting

①



Cut the tube to the required length. The cut edge of the tube should be at a right angle to the tube center line. The tolerance of a right angle should be  $90^{\circ} \pm 1^{\circ}$ .

②

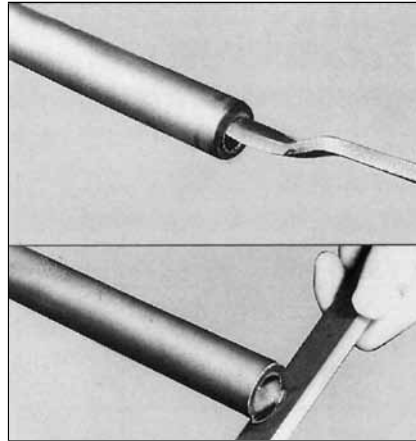

Remove all burrs from the inside and outside at the tube cut end. Exercise care not to deform the tube or cause damages such as deep scratches on the tube outside surface.

③

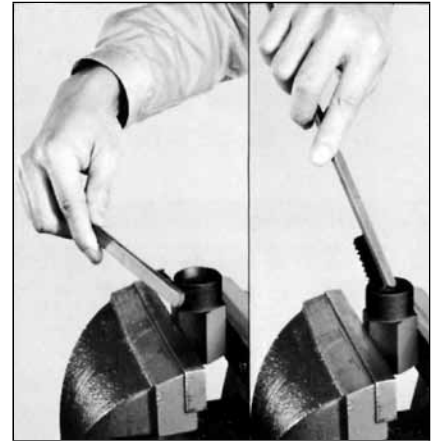

Firmly clamp the tightening jig PJA (refer to page 36) in a bench vice. Coat the threads and tapered portion with lubricant

④

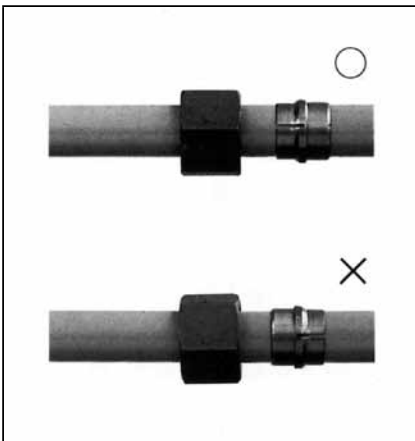

Insert the nut and the sleeve in correct order and direction on to the tube. Particular attention should be made to the direction of the sleeve.

⑤

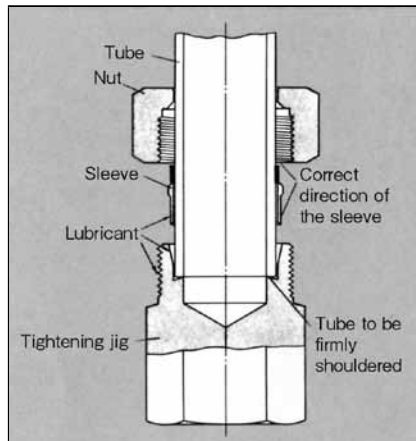

Insert the tube with the nut and the sleeve into the tightening jig. The tube end must be firmly contacting the shoulder of the tightening jig.

⑥

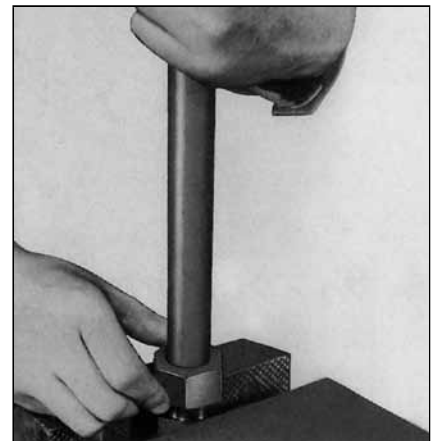

Finger tighten the nut.

⑦

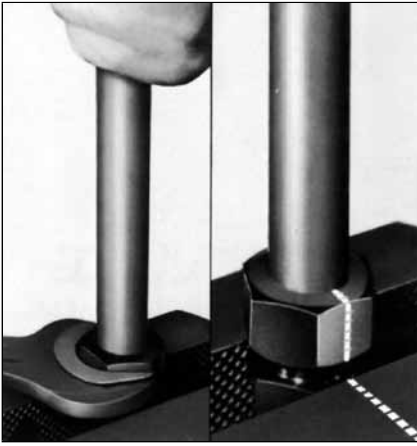

Confirm the grip point. While turning the tube lightly with the hand, tighten the nut until the tube can no longer be turned. This point is referred to as the grip point. It is at this point that the sleeve begins to bite into the tube. Draw an identification matching mark so that the amount of tightening can be determined.

⑧



Tighten the nut 1-1/4 turn with a spanner from the grip point. (See note)

With the above procedure the sleeve has firmly bitten and seated into the tube.

**⚠ WARNING: Provide adequate work space and assure safety when tightening the nut. The wrench must be properly fitted to the nut when tightening.**

**⚠ CAUTION: If tightening is insufficient, leakage may occur and the tube may pull out. Excessively tightening the nut can damage the fitting and impair its function.**

⑨

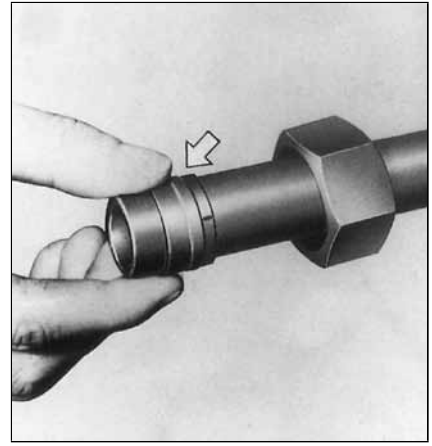

Loosen the nut and check the sleeve biting condition.

- The surface of the sleeve should be free of scratches and nicks.
- The sleeve edge should be several millimeters apart from the tube end.
- The sleeve should not move axially on the tube although peripheral rotating movement is permissible.

## 2) Resetting

⑩



When installing a tube that has been preset to a fitting body, the surface of the sleeve and the tapered surface on the fitting body must be clean and free from metal cuttings and other foreign materials.

Tighten the nut with the fingers to the fitting body and the nut should be capable of being tightened more than 2 turns.

**⚠ WARNING: Do not disassemble the fitting under pressurized.**

**⚠ CAUTION: After presetting, blow compressed air on the sleeve and the taper bore surface on the fitting body to remove all foreign matters before assembling. If a foreign matter becomes caught, the sealing function can be impaired.**

⑪

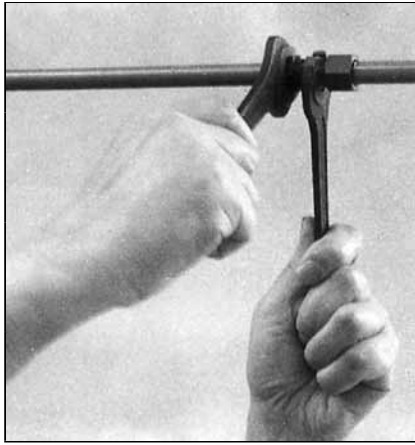

Use a standard single head spanner to tighten and search for a point where the torque suddenly increases (this point is referred to as the sharp torque rising point).

⑫

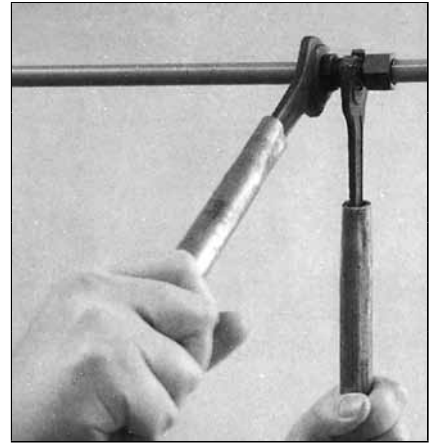

Further tighten the nut 1/4 turn from the sharp torque rising point. To prevent the nut and fitting body from co-rotating, hold the fitting body with another spanner.

**⚠ WARNING: Provide adequate work space and ascertain safety when tightening the nut. The wrench must be properly fitted to the nut when tightening.**

**⚠ CAUTION: If tightening is insufficient, leakage can occur and the tube may slip. Excessively tightening the nut can damage the fitting and impair its function.**



## Union KUA

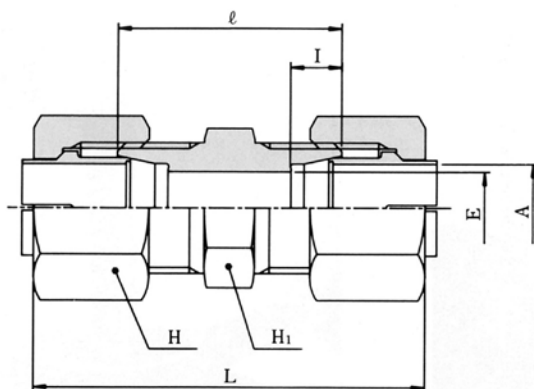

unit: mm

Part No.	Tube OD A	E	Hex.		I	ℓ	Approx. L	Weight (kg)
			H <sub>1</sub>	H				
KUA06-000CE	6	4.5	10	12	5.5	20	38.6	0.020
KUA08-000CE	8	6	12	14	5.5	22	42	0.030
KUA10-000CE	10	8	14	17	5.5	23	43	0.040
KUA12-000CE	12	10	17	19	6	24	44	0.051
KUA16-000CE	16	13	22	27	8	29	54.2	0.130
KUA20-000CE	20	17	27	30	8	30	58.6	0.154
KUA25-000CE	25	22	32	36	9	33	62.6	0.225
KUA30-000CE	30	26	36	41	9	35	65.6	0.291

## Bulkhead Union KSU

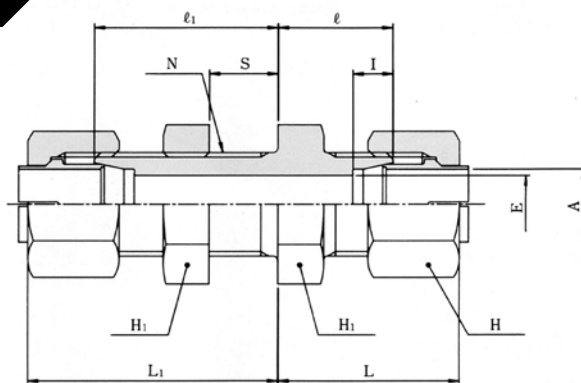

unit: mm

Part No.	Tube OD A	E	Hex.		I	ℓ <sub>1</sub>	ℓ	Approx. L <sub>1</sub>	Approx. L	N	Max. S	Weight (kg)
			H <sub>1</sub>	H								
KSU06-000CE	6	4.5	14	12	5.5	26	13	35.3	22.3	M10×1	13	0.035
KSU08-000CE	8	6	17	14	5.5	27.5	14.5	37.5	24.5	M12×1	13	0.055
KSU10-000CE	10	8	19	17	5.5	29	16	39	26	M14×1	13	0.072
KSU12-000CE	12	10	22	19	6	29	16	39	26	M16×1	13	0.091
KSU16-000CE	16	13	27	27	8	34	19	46.6	31.6	M22×1.5	15	0.202
KSU20-000CE	20	17	32	30	8	36	21	50.3	35.3	M26×1.5	15	0.261
KSU25-000CE	25	22	36	36	9	37.5	22.5	52.3	37.3	M32×1.5	15	0.357
KSU30-000CE	30	26	41	41	9	39	23.5	54.3	38.8	M36×1.5	15	0.453

**CAUTION** : This type of fitting is designed to be used for wall penetration. When used in the place of strong vibration and/or pressure fluctuation, proper vibration measures such as fixing the piping by clamp are required.

## Union Elbow KLA

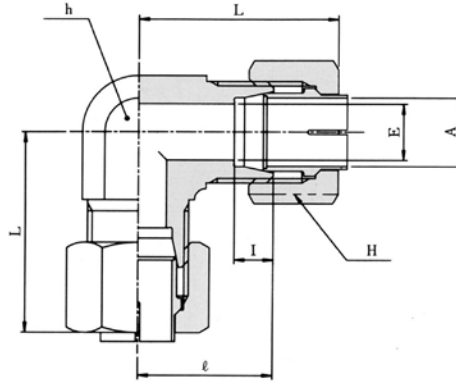

unit: mm

Part No.	Tube OD A	E	Flats h	Hex. H	I	l	Approx. L	Weight (kg)
KLA06-000CE	6	4.5	12	12	5.5	17	26.3	0.032
KLA08-000CE	8	6	12	14	5.5	17.5	27.5	0.037
KLA10-000CE	10	8	14	17	5.5	20	30	0.055
KLA12-000CE	12	10	17	19	6	21	31	0.080
KLA16-000CE	16	13	24	27	8	28	40.6	0.194
KLA20-000CE	20	17	27	30	8	30.5	44.8	0.234
KLA25-000CE	25	22	36	36	9	35.5	50.3	0.438
KLA30-000CE	30	26	41	41	9	39.5	54.8	0.605

## Union Tee KTA

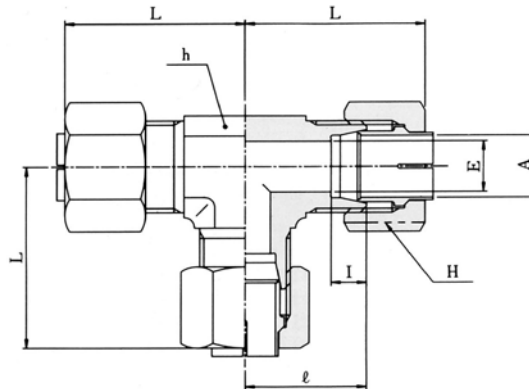

unit: mm

Part No.	Tube OD A	E	Flats h	Hex. H	I	l	Approx. L	Weight (kg)
KTA06-000CE	6	4.5	12	12	5.5	17	26.3	0.044
KTA08-000CE	8	6	12	14	5.5	17.5	27.5	0.053
KTA10-000CE	10	8	14	17	5.5	20	30	0.076
KTA12-000CE	12	10	17	19	6	21	31	0.095
KTA16-000CE	16	13	24	27	8	28	40.6	0.268
KTA20-000CE	20	17	27	30	8	30.5	44.8	0.332
KTA25-000CE	25	22	36	36	9	35.5	50.3	0.572
KTA30-000CE	30	26	41	41	9	39.5	54.8	0.772

# Male Connector KCT

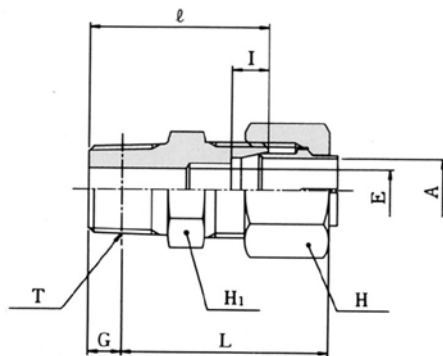

unit: mm

Part No.	Tube OD A	(R) T	Minimum Opening E	Gauge Length G	Hex.		I	$l$	Approx. L	Weight (kg)
					H <sub>1</sub>	H				
KCT06-010CE	6	1/8	4.5	3.97	12	12	5.5	22.5	27.8	0.017
KCT06-020CE	6	1/4	4.5	6.01	14	12	5.5	26.5	29.8	0.024
KCT06-030CE	6	3/8	4.5	6.35	17	12	5.5	29	31.9	0.039
KCT08-010CE	8	1/8	4.5	3.97	12	14	5.5	23	29	0.019
KCT08-020CE	8	1/4	6	6.01	14	14	5.5	27	31	0.026
KCT08-030CE	8	3/8	6	6.35	17	14	5.5	29.5	33.1	0.042
KCT10-020CE	10	1/4	7	6.01	14	17	5.5	28	32	0.032
KCT10-030CE	10	3/8	8	6.35	17	17	5.5	30	33.7	0.044
KCT12-020CE	12	1/4	7	6.01	17	19	6	29	33	0.038
KCT12-030CE	12	3/8	9	6.35	17	19	6	30	33.7	0.043
KCT12-040CE	12	1/2	10	8.16	22	19	6	36	37.8	0.078
KCT16-030CE	16	3/8	9	6.35	22	27	8	33.5	39.8	0.092
KCT16-040CE	16	1/2	12	8.16	22	27	8	37.5	41.9	0.105
KCT20-040CE	20	1/2	12	8.16	27	30	8	37.5	43.6	0.116
KCT20-060CE	20	3/4	16	9.53	27	30	8	39.5	44.3	0.140
KCT25-060CE	25	3/4	16	9.53	32	36	9	42.5	47.8	0.189
KCT25-080CE	25	1	20	10.39	36	36	9	46.5	50.9	0.249
KCT30-060CE	30	3/4	16	9.53	36	41	9	44.5	50.3	0.253
KCT30-080CE	30	1	22	10.39	36	41	9	47.5	52.4	0.262
KCT30-100CE	30	1 1/4	26	12.7	46	41	9	51	53.6	0.402

# Bulkhead Male Connector KSC

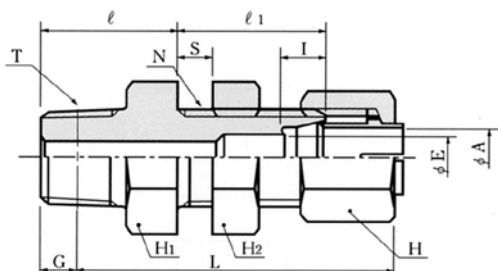

unit: mm

Part No.	Tube OD A	(R) T	E	Gauge Length G	Hex.			l	ℓ	ℓ <sub>1</sub>	Approx. L	N	Max. S	Weight (kg)
					H <sub>1</sub>	H <sub>2</sub>	H							
KSC06-010CE	6	1/8	4	3.97	14	14	12	5.5	15	26	46.3	M10×1	13	0.033
KSC06-020CE	6	1/4	4.5	6.01	14	14	12	5.5	19	26	48.3	M10×1	13	0.038
KSC08-010CE	8	1/8	4	3.97	17	17	14	5.5	16	27.5	49.5	M12×1	13	0.051
KSC08-020CE	8	1/4	6	6.01	17	17	14	5.5	20	27.5	51.5	M12×1	13	0.052
KSC10-020CE	10	1/4	7	6.01	19	19	17	5.5	21	29	54	M14×1	13	0.066
KSC10-030CE	10	3/8	8	6.35	19	19	17	5.5	22	29	54.7	M14×1	13	0.074
KSC12-020CE	12	1/4	7	6.01	22	22	19	6	21	29	54	M16×1	13	0.094
KSC12-030CE	12	3/8	9	6.35	22	22	19	6	22	29	54.7	M16×1	13	0.088
KSC16-030CE	16	3/8	9	6.35	27	27	27	8	23	34	63.3	M22×1.5	15	0.163
KSC16-040CE	16	1/2	12	8.16	27	27	27	8	27	34	65.4	M22×1.5	15	0.176
KSC20-040CE	20	1/2	12	8.16	32	32	30	8	29	36	71.1	M26×1.5	15	0.243
KSC20-060CE	20	3/4	16	9.53	32	32	30	8	31	36	71.8	M26×1.5	15	0.251
KSC25-060CE	25	3/4	16	9.53	36	36	36	9	32	37.5	74.8	M32×1.5	15	0.357
KSC25-080CE	25	1	20	10.39	36	36	36	9	35	37.5	76.9	M32×1.5	15	0.420
KSC30-060CE	30	3/4	16	9.53	41	41	41	9	32.5	39	77.3	M36×1.5	15	0.430
KSC30-080CE	30	1	22	10.39	41	41	41	9	35.5	39	79.4	M36×1.5	15	0.457
KSC30-100CE	30	1 1/4	26	12.7	46	41	41	9	39	39	80.6	M36×1.5	15	0.554

**⚠ CAUTION :** This type of fitting is designed to be used for wall penetration. When used in the place of strong vibration and/or pressure fluctuation, proper vibration measures such as fixing the piping by clamp are required.

# Extended Male Connector KCC

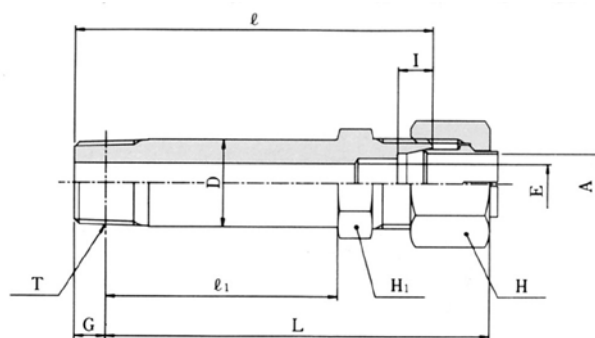

unit: mm

Part No.	Tube OD A	(R) T	Minimum Opening E	Gauge Length G	Hex.		I	D	ℓ	ℓ <sub>1</sub>	Approx. L	Weight (kg)
					H <sub>1</sub>	H						
KCC06-010CE	6	1/8	4	3.97	12	12	5.5	10.5	49.5	33	54.8	0.031
KCC08-010CE	8	1/8	4	3.97	12	14	5.5	10.5	51	34	57	0.037
KCC08-020CE	8	1/4	6	6.01	14	14	5.5	14	55	36	59	0.055
KCC10-020CE	10	1/4	7	6.01	14	17	5.5	14	57	37	61	0.054
KCC10-030CE	10	3/8	8	6.35	17	17	5.5	17	59	37.5	62.7	0.085
KCC12-020CE	12	1/4	6	6.01	17	19	6	14	59	38	63	0.072
KCC12-030CE	12	3/8	9	6.35	17	19	6	17	60	38.5	63.7	0.079
KCC16-030CE	16	3/8	9	6.35	22	27	8	17.5	70	45	76.3	0.151
KCC16-040CE	16	1/2	12	8.16	22	27	8	22	74	47.3	78.4	0.178
KCC20-040CE	20	1/2	12	8.16	27	30	8	27	76	49.5	90.3	0.259
KCC20-060CE	20	3/4	16	9.53	27	30	8	27	79.5	51.5	84.3	0.249
KCC25-060CE	25	3/4	16	9.53	32	36	9	27.5	86	55	91.3	0.329
KCC25-080CE	25	1	20	10.39	36	36	9	34.5	91.5	58	95.9	0.473
KCC30-060CE	30	3/4	16	9.53	36	41	9	27.5	89.5	56.5	95.3	0.412
KCC30-080CE	30	1	22	10.39	36	41	9	34.5	93.5	59.5	98.4	0.471
KCC30-100CE	30	1 1/4	26	12.7	46	41	9	43	98	61.3	100.6	0.743

# Male Elbow KLN

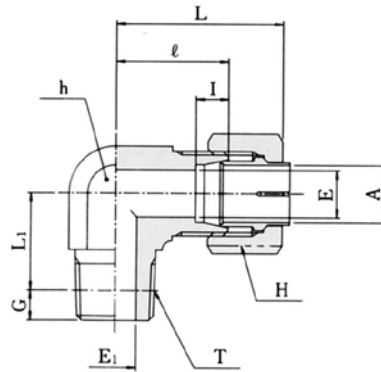

unit: mm

Part No.	Tube OD A	(R) T	E	E <sub>1</sub>	Gauge Length G	Flats h	Hex. H	I	ℓ	Approx. L	Approx. L <sub>1</sub>	Weight (kg)
KLN06-010CE	6	1/8	4.5	4.5	3.97	12	12	5.5	17	26.3	14.5	0.027
KLN06-020CE	6	1/4	4.5	7	6.01	14	12	5.5	17	26.3	17	0.035
KLN08-010CE	8	1/8	6	4.5	3.97	12	14	5.5	17.5	27.5	15	0.029
KLN08-020CE	8	1/4	6	7	6.01	14	14	5.5	17.5	27.5	18	0.038
KLN10-020CE	10	1/4	8	7	6.01	14	17	5.5	20	30	18	0.046
KLN10-030CE	10	3/8	8	9	6.35	17	17	5.5	21	31	19.7	0.066
KLN12-020CE	12	1/4	10	7	6.01	17	19	6	21	31	19	0.064
KLN12-030CE	12	3/8	10	9	6.35	17	19	6	21	31	19.7	0.071
KLN12-040CE	12	1/2	10	12	8.16	24	19	6	24	34	25.8	0.134
KLN16-030CE	16	3/8	13	9	6.35	24	27	8	28	40.6	24.7	0.167
KLN16-040CE	16	1/2	13	12	8.16	24	27	8	28	40.6	25.8	0.167
KLN20-040CE	20	1/2	17	12	8.16	27	30	8	30.5	44.8	27.8	0.230
KLN20-060CE	20	3/4	17	16	9.53	30	30	8	30.5	44.8	28.5	0.258
KLN25-060CE	25	3/4	22	16	9.53	36	36	9	35.5	50.3	31.5	0.397
KLN25-080CE	25	1	22	22	10.39	36	36	9	35.5	50.3	33.6	0.412
KLN30-060CE	30	3/4	26	16	9.53	41	41	9	39.5	54.8	34.5	0.550
KLN30-080CE	30	1	26	22	10.39	41	41	9	39.5	54.8	36.6	0.555
KLN30-100CE	30	1 1/4	26	31	12.7	46	41	9	41	56.3	42.3	0.670

# Stud Elbow (Type-C) KMC

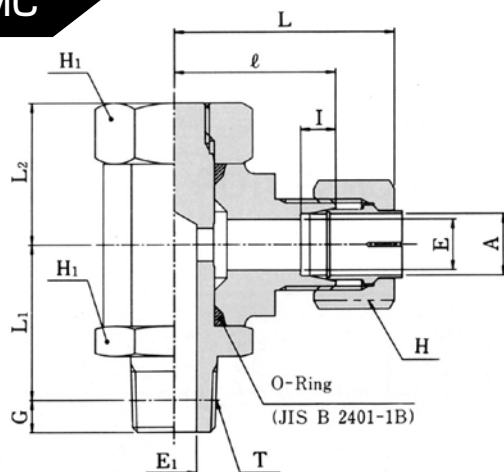

unit: mm

Part No.	Tube OD A	(R) T	E	E <sub>1</sub>	Gauge Length G	Hex.		I	ℓ	L <sub>1</sub>	L <sub>2</sub>	Approx. L	O-Ring	Weight (kg)
						H <sub>1</sub>	H							
KMC06-010CE	6	1/8	4.5	4	3.97	17	12	5.5	19	22	19	28.3	P9	0.078
KMC08-010CE	8	1/8	6	4	3.97	17	14	5.5	19.5	22	19	29.5	P9	0.080
KMC08-020CE	8	1/4	6	7	6.01	22	14	5.5	25.5	26	23	35.5	P12.5	0.150
KMC10-020CE	10	1/4	8	7	6.01	22	17	5.5	26	26	23	36	P12.5	0.152
KMC12-030CE	12	3/8	10	9	6.35	27	19	6	29	31	28	39	P16	0.268
KMC16-040CE	16	1/2	13	12	8.16	27	27	8	31	35	30	43.6	P18	0.342
KMC20-060CE	20	3/4	17	16	9.53	36	30	8	38	44.5	38	52.3	P25	0.754
KMC25-080CE	25	1	22	22	10.39	46	36	9	45.5	53.6	44	60.3	P32	1.264
KMC30-080CE	30	1	26	22	12.7	46	41	9	46	53.6	44	61.3	P32	1.712

⚠ CAUTION : Fitting is designed to be fixedly used. Never use it for rotating purpose as replacement of swivel joint.

# Extended Male Elbow KLL

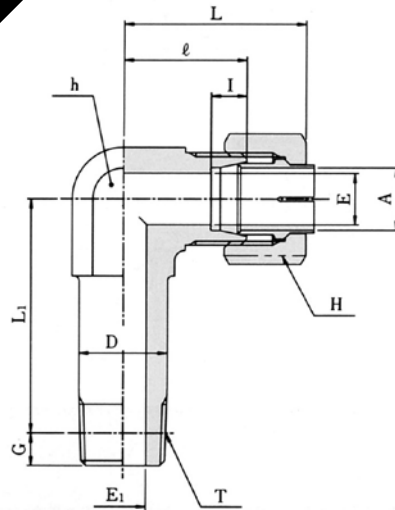

unit: mm

Part No.	Tube OD A	(R) T	E	E <sub>1</sub>	Gauge Length G	Flats h	Hex. H	I	D	ℓ	Approx. L	Approx. L <sub>1</sub>	Weight (kg)
KLL06-010CE	6	1/8	4.5	4	3.97	14	12	5.5	12	17	26.3	33	0.046
KLL08-010CE	8	1/8	6	4	3.97	14	14	5.5	12	19.5	29.5	36	0.055
KLL08-020CE	8	1/4	6	7	6.01	17	14	5.5	16	19.5	29.5	41	0.055
KLL10-020CE	10	1/4	8	7	6.01	17	17	5.5	16	20	30	43	0.093
KLL10-030CE	10	3/8	8	9	6.35	19	17	5.5	18	21	31	45.7	0.118
KLL12-020CE	12	1/4	10	7	6.01	17	19	6	16	21	31	46	0.087
KLL12-030CE	12	3/8	10	9	6.35	19	19	6	18	21	31	45.7	0.119
KLL16-030CE	16	3/8	13	9	6.35	22	27	8	23	27	39.6	61.5	0.243
KLL16-040CE	16	1/2	13	12	8.16	22	27	8	23	27	39.6	60.8	0.230
KLL20-040CE	20	1/2	17	12	8.16	27	30	8	26	30.5	44.8	66.8	0.357
KLL20-060CE	20	3/4	17	16	9.53	30	30	8	28	30.5	44.8	67.5	0.369
KLL25-060CE	25	3/4	22	16	9.53	36	36	9	35	35.5	50.3	78.5	0.410
KLL25-080CE	25	1	22	22	10.39	36	36	9	35	35.5	50.3	79.6	0.624
KLL30-060CE	30	3/4	26	16	9.53	36	41	9	35	37	52.3	78.5	0.680
KLL30-080CE	30	1	26	22	10.39	36	41	9	35	37	52.3	89.6	0.866
KLL30-100CE	30	1 1/4	26	31	12.70	46	41	9	44	41	56.3	85.3	1.044

# Male Branch Tee KTN

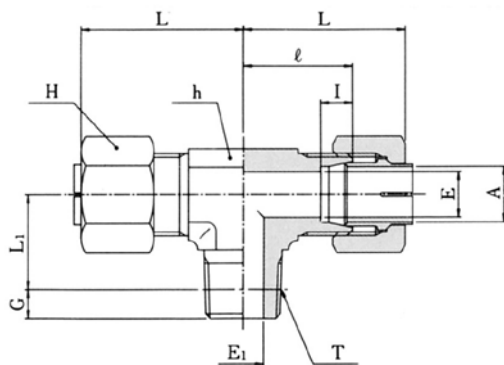

unit: mm

Part No.	Tube OD A	(R) T	E	E <sub>1</sub>	Gauge Length G	Flats h	Hex. H	I	ℓ	Approx. L	Approx. L <sub>1</sub>	Weight (kg)
KTN06-010CE	6	1/8	4.5	4.5	3.97	12	12	5.5	17	26.3	14.5	0.036
KTN08-010CE	8	1/8	6	4.5	3.97	12	14	5.5	17.5	27.5	15	0.044
KTN08-020CE	8	1/4	6	7	6.01	14	14	5.5	17.5	27.5	18	0.052
KTN10-020CE	10	3/8	8	7	6.01	14	17	5.5	20	30	18	0.064
KTN10-030CE	10	3/8	8	9	6.35	17	17	5.5	21	31	19.7	0.086
KTN12-020CE	12	1/4	10	7	6.01	17	19	6	21	31	19	0.088
KTN12-030CE	12	3/8	10	9	6.35	17	19	6	21	31	19.7	0.089
KTN16-030CE	16	3/8	13	9	6.35	24	27	8	28	40.6	24.7	0.178
KTN16-040CE	16	1/2	13	12	8.16	24	27	8	28	40.6	25.8	0.239
KTN20-040CE	20	1/2	17	12	8.16	27	30	8	30.5	44.8	27.8	0.315
KTN20-060CE	20	3/4	17	16	9.53	30	30	8	30.5	44.8	28.5	0.357
KTN25-060CE	25	3/4	22	16	9.53	36	36	9	35.5	50.3	31.5	0.525
KTN25-080CE	25	1	22	22	10.39	36	36	9	35.5	50.6	33.6	0.540
KTN30-060CE	30	3/4	26	16	9.53	41	41	9	39.5	54.8	34.5	0.727
KTN30-080CE	30	1	26	22	10.39	41	41	9	39.5	54.8	36.6	0.712
KTN30-100CE	30	1 1/4	26	31	12.7	46	41	9	41	56.3	42.3	1.185

# Male Run Tee KTK

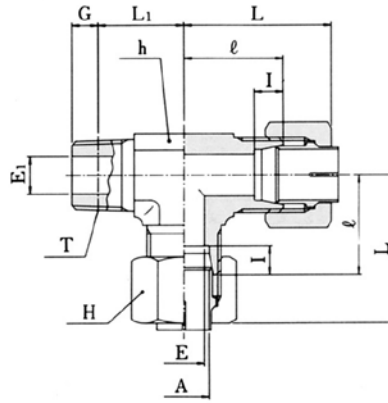

unit: mm

Part No.	Tube OD A	(R) T	E	E <sub>1</sub>	Gauge Length G	Flats h	Hex. H	l	ℓ	Approx. L	Approx. L <sub>1</sub>	Weight (kg)
KTK06-010CE	6	1/8	4.5	4.5	3.97	14	12	5.5	18	27.3	15	0.050
KTK08-010CE	8	1/8	6	4.5	3.97	14	14	5.5	18	28.5	15	0.054
KTK08-020CE	8	1/4	6	7	6.01	17	14	5.5	20.5	30.5	18	0.075
KTK10-020CE	10	1/4	8	7	6.01	17	17	5.5	21	31	18	0.094
KTK10-030CE	10	3/8	8	9	6.35	19	17	5.5	21	31	19.7	0.109
KTK12-020CE	12	1/4	10	7	6.01	17	19	6	22	32	19	0.092
KTK12-030CE	12	3/8	10	9	6.35	19	19	6	22	32	19.7	0.104
KTK16-030CE	16	3/8	13	9	6.35	24	27	8	28	40.6	24.7	0.219
KTK16-040CE	16	1/2	13	12	8.16	24	27	8	28	40.6	25.8	0.245
KTK20-040CE	20	1/2	17	12	8.16	27	30	8	30.5	44.8	27.8	0.308
KTK20-060CE	20	3/4	17	16	9.53	30	30	8	30.5	44.8	28.5	0.355
KTK25-060CE	25	3/4	22	16	9.53	36	36	9	35.5	50.3	31.5	0.516
KTK25-080CE	25	1	22	22	10.39	36	36	9	35.5	50.3	33.6	0.540
KTK30-060CE	30	3/4	26	16	9.53	41	41	9	39.5	54.8	34.5	0.759
KTK30-080CE	30	1	26	22	10.39	41	41	9	39.5	54.8	36.6	0.801
KTK30-100CE	30	1 1/4	26	31	12.7	46	41	9	41	56.3	42.3	0.951

# Female Connector KSA

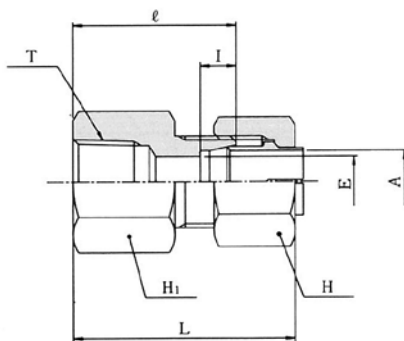

unit: mm

Part No.	Tube OD A	(Rc) T	E	Hex.		l	ℓ	Approx. L	Weight (kg)
				H <sub>1</sub>	H				
KSA06-010CE	6	1/8	4.5	14	12	5.5	23	32.3	0.019
KSA06-020CE	6	1/4	4.5	19	12	5.5	27	36.3	0.043
KSA08-010CE	8	1/8	6	14	14	5.5	23.5	33.5	0.021
KSA08-020CE	8	1/4	6	19	14	5.5	27.5	37.5	0.043
KSA10-020CE	10	1/4	8	19	17	5.5	28	38	0.050
KSA10-030CE	10	3/8	8	24	17	5.5	30	40	0.075
KSA12-020CE	12	1/4	10	19	19	6	28	38	0.052
KSA12-030CE	12	3/8	10	24	19	6	29	39	0.072
KSA16-030CE	16	3/8	13	24	27	8	31	43.6	0.107
KSA16-040CE	16	1/2	13	27	27	8	36.5	49.1	0.130
KSA20-040CE	20	1/2	17	27	30	8	36.5	50.8	0.135
KSA20-060CE	20	3/4	17	36	30	8	38.5	52.8	0.215
KSA25-060CE	25	3/4	22	36	36	9	39.5	54.3	0.235
KSA25-080CE	25	1	22	41	36	9	43	57.8	0.343
KSA30-060CE	30	3/4	26	36	41	9	40	55.3	0.254
KSA30-080CE	30	1	26	41	41	9	43.5	58.8	0.385
KSA30-100CE	30	1 1/4	26	55	41	9	47	62.3	0.532

# Bulkhead Female Connector KSS

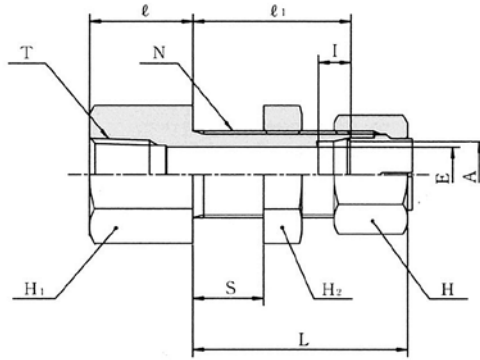

unit: mm

Part No.	Tube OD A	(Rc) T	E	Hex.			I	l <sub>1</sub>	l	Approx. L	N	Max. S	Weight (kg)
				H <sub>1</sub>	H <sub>2</sub>	H							
KSS06-020CE	6	¼	4.5	19	14	12	5.5	26	19	35.3	M10×1	13	0.058
KSS08-010CE	8	⅙	6	17	17	14	5.5	27.5	14	36.8	M12×1	13	0.043
KSS08-020CE	8	¼	6	19	17	14	5.5	27.5	19	37.5	M12×1	13	0.059
KSS10-020CE	10	¼	8	19	19	17	5.5	29	19	39	M14×1	13	0.082
KSS10-030CE	10	⅜	8	24	19	17	5.5	29	20	39	M14×1	13	0.089
KSS12-020CE	12	¼	10	22	22	19	6	29	19	39	M16×1	13	0.081
KSS12-030CE	12	⅜	10	24	22	19	6	29	20	39	M16×1	13	0.098
KSS16-030CE	16	⅜	13	27	27	27	8	34	20	46.6	M22×1.5	15	0.159
KSS16-040CE	16	½	13	27	27	27	8	34	25.5	46.6	M22×1.5	15	0.181
KSS20-040CE	20	½	17	32	32	30	8	36	25.5	50.3	M26×1.5	15	0.229
KSS20-060CE	20	¾	17	36	32	30	8	36	27.5	50.3	M26×1.5	15	0.291
KSS25-060CE	25	¾	22	36	36	36	9	37.5	28	52.3	M32×1.5	15	0.342
KSS25-080CE	25	1	22	41	36	36	9	37.5	31.5	52.3	M32×1.5	15	0.341
KSS30-060CE	30	¾	26	41	41	41	9	39	28	54.3	M36×1.5	15	0.404
KSS30-080CE	30	1	26	41	41	41	9	39	31.5	54.3	M36×1.5	15	0.420
KSS30-100CE	30	1¼	26	55	41	41	9	39	35	54.3	M36×1.5	15	0.611

**⚠ CAUTION :** This type of fitting is designed to be used for wall penetration. When used in the place of strong vibration and/or pressure fluctuation, proper vibration measures such as fixing the piping by clamp are required.

# Female Elbow KLF

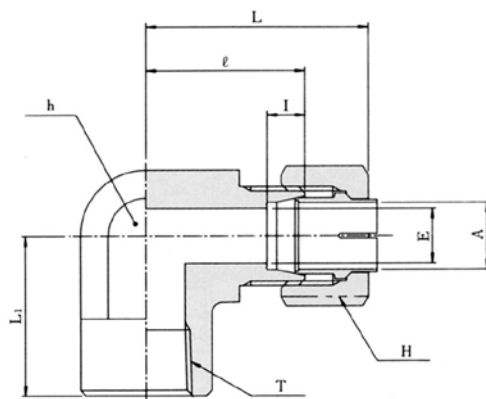

unit: mm

Part No.	Tube OD A	(Rc) T	E	Flats h	Hex. H	l	$\ell$	L <sub>1</sub>	Approx. L	Weight (kg)
KLF06-010CE	6	1/8	4.5	14	12	5.5	17	23	26.3	0.035
KLF08-010CE	8	1/8	6	14	14	5.5	17.5	23	27.5	0.046
KLF08-020CE	8	1/4	6	17	14	5.5	20.5	27.5	30.5	0.062
KLF10-020CE	10	1/4	8	17	17	5.5	21	27.5	31	0.060
KLF10-030CE	10	3/8	8	24	17	5.5	24	29	34	0.123
KLF12-020CE	12	1/4	10	17	19	6	21	27.5	31	0.078
KLF12-030CE	12	3/8	10	24	19	6	24	29	34	0.128
KLF16-030CE	16	3/8	13	24	27	8	28	29	40.6	0.163
KLF16-040CE	16	1/2	13	30	27	8	30	33	42.6	0.256
KLF20-040CE	20	1/2	17	30	30	8	30	33	44.3	0.256
KLF20-060CE	20	3/4	17	36	30	8	35.5	36	49.8	0.380
KLF25-060CE	25	3/4	22	36	36	9	35.5	36	50.3	0.385
KLF25-080CE	25	1	22	46	36	9	40	40	54.8	0.636
KLF30-060CE	30	3/4	26	41	41	9	40	40	55.3	0.605
KLF30-080CE	30	1	26	46	41	9	40	40	55.3	0.805
KLF30-100CE	30	1 1/4	26	55	41	9	44.5	45	59.8	1.525

# Female Run Tee KTF

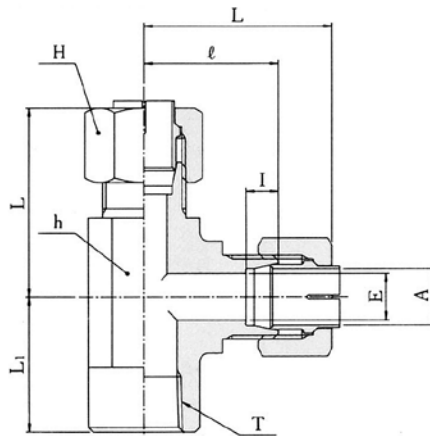

unit: mm

Part No.	Tube OD A	(Rc) T	E	Flats h	Hex. H	l	l	Approx. L	L <sub>1</sub>	Weight (kg)
KTF06-010CE	6	1/8	4.5	14	12	5.5	18	27.3	19	0.049
KTF08-010CE	8	1/8	6	14	14	5.5	18	28	19	0.054
KTF08-020CE	8	1/4	6	17	14	5.5	20.5	30.5	24	0.056
KTF10-020CE	10	1/4	8	17	17	5.5	21	31	24	0.090
KTF10-030CE	10	3/8	8	24	17	5.5	24	34	29	0.090
KTF12-020CE	12	1/4	10	17	19	6	21	31	24	0.085
KTF12-030CE	12	3/8	10	24	19	6	24	34	29	0.163
KTF16-030CE	16	3/8	13	24	27	8	28	40.6	29	0.202
KTF16-040CE	16	1/2	13	30	27	8	30	42.6	33	0.405
KTF20-040CE	20	1/2	17	30	30	8	30	44.3	33	0.359
KTF20-060CE	20	3/4	17	36	30	8	35.5	49.8	36	0.516
KTF25-060CE	25	3/4	22	36	36	9	35.5	50.3	36	0.514
KTF25-080CE	25	1	22	46	36	9	40	54.8	40	0.595
KTF30-060CE	30	3/4	26	41	41	9	40	55.3	40	0.725
KTF30-080CE	30	1	26	46	41	9	40	55.3	40	0.889
KTF30-100CE	30	1 1/4	26	55	41	9	44.5	59.8	45	1.439



## Connector For Pressure Gauge KGA

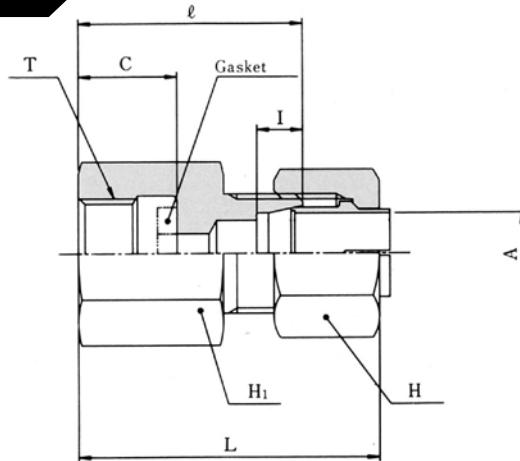

unit: mm

Part No.	Tube OD A	(G) T	C	Hex.		I	$\ell$	Approx. L	Gasket or KP-B KP-D	Weight (kg)
				H <sub>1</sub>	H					
KGA06-020CE	6	¼	14	19	12	5.5	28	37.3	-01	0.040
KGA06-030CE	6	⅜	15	24	12	5.5	30	39.3	-02	0.066
KGA06-040CE	6	½	16	30	12	5.5	32	41.3	-03	
KGA08-020CE	8	¼	14	19	14	5.5	28.5	38.5	-01	0.043
KGA08-030CE	8	⅜	15	24	14	5.5	30.5	40.5	-02	0.071
KGA08-040CE	8	½	16	30	14	5.5	32.5	42.5	-03	
KGA10-020CE	10	¼	14	19	17	5.5	29	39	-01	0.051
KGA10-030CE	10	⅜	15	24	17	5.5	31	41	-02	0.076
KGA10-040CE	10	½	16	30	17	5.5	33	43	-03	0.115
KGA12-020CE	12	¼	14	19	19	6	29	39	-01	0.053
KGA12-030CE	12	⅜	15	24	19	6	31	41	-02	0.069
KGA12-040CE	12	½	16	30	19	6	33	43	-03	0.119

Gaskets are not included in the standard packages, and must be ordered when required.

## Gasket KP-B/KP-D

unit: mm

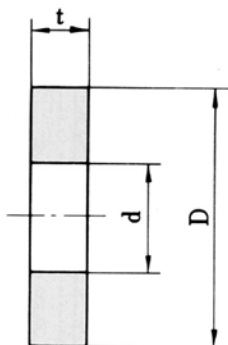

Part No.	d	D	t	Material
KP-B-01	6	11	3	Chrome Tanning Leather
KP-B-02	6	14	3	
KP-B-03	6	18	3	
KP-D-01	6	11	2	Phosphorus Deoxidized Copper
KP-D-02	6	14	2	
KP-D-03	6	18	2	

# Male Seat Hose Connection Union KUC

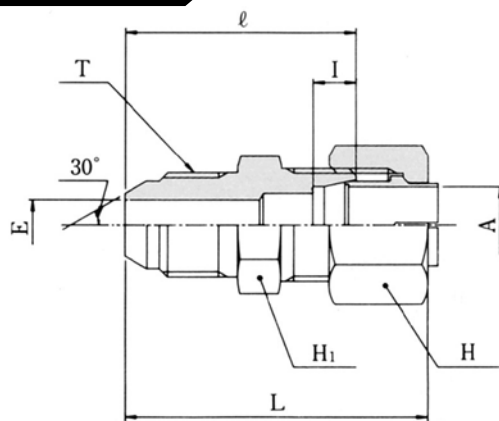

unit: mm

Part No.	Tube OD A	(G) T	Minimum Opening E	Hex.		I	ℓ	Approx. L	Weight (kg)
				H <sub>1</sub>	H				
KUC08-020CE	8	¼	5.5	14	14	5.5	29.5	39.5	0.030
KUC08-030CE	8	⅜	6	17	14	5.5	32.5	42.5	0.041
KUC10-020CE	10	¼	5.5	14	17	5.5	30	40	0.035
KUC10-030CE	10	⅜	8	17	17	5.5	33	43	0.046
KUC12-020CE	12	¼	5.5	17	19	6	31.5	41.5	0.043
KUC12-030CE	12	⅜	8	17	19	6	33	43	0.049
KUC12-040CE	12	½	10	22	19	6	36.5	46.5	0.071
KUC16-030CE	16	⅜	8	22	27	8	36	48.6	0.093
KUC16-040CE	16	½	10	22	27	8	38.5	51.1	0.105
KUC20-040CE	20	½	10	27	30	8	39	53.3	0.132
KUC20-060CE	20	¾	16	27	30	8	40.5	54.8	0.140
KUC25-060CE	25	¾	16	32	36	9	43.5	58.3	0.192
KUC25-080CE	25	1	21.5	36	36	9	45	59.8	0.224
KUC30-060CE	30	¾	16	36	41	9	44.5	59.8	0.243
KUC30-080CE	30	1	21.5	36	41	9	45.5	60.8	0.252

# Male Seat Hose Connection Union Elbow KLD

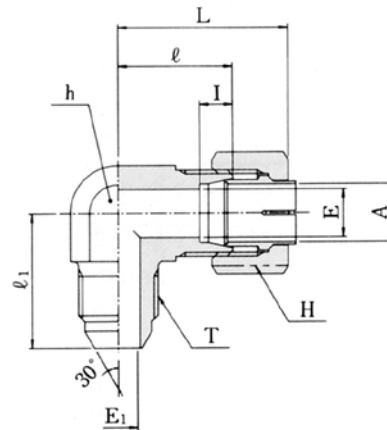

unit: mm

Part No.	Tube OD A	(G) T	E	E <sub>1</sub>	Flats h	Hex. H	I	l <sub>1</sub>	l	Approx. L	Weight (kg)
KLD08-020CE	8	¼	6	5.5	14	14	5.5	26	17.5	27.5	0.041
KLD08-030CE	8	⅜	6	8	17	14	5.5	29	20.5	30.5	0.063
KLD10-020CE	10	¼	8	5.5	14	17	5.5	26	20	30	0.048
KLD10-030CE	10	⅜	8	8	17	17	5.5	29	21	31	0.068
KLD12-020CE	12	¼	10	5.5	17	19	6	27	21	31	0.075
KLD12-030CE	12	⅜	10	8	17	19	6	29	21	31	0.073
KLD12-040CE	12	½	10	10	24	19	6	34	24	34	0.137
KLD16-030CE	16	⅜	13	8	24	27	8	32	28	40.6	0.159
KLD16-040CE	16	½	13	10	24	27	8	34	28	40.6	0.170
KLD20-040CE	20	½	17	10	27	30	8	37	30.5	44.8	0.125
KLD20-060CE	20	¾	17	16	30	30	8	41	30.5	44.8	0.264
KLD25-060CE	25	¾	22	16	36	36	9	42	35.5	50.3	0.397
KLD25-080CE	25	1	22	21.5	36	36	9	46	35.5	50.3	0.421
KLD30-060CE	30	¾	26	16	41	41	9	47	39.5	54.8	0.527
KLD30-080CE	30	1	26	21.5	41	41	9	49	39.5	54.8	0.529

## Male Seat Hose Connection Bulkhead Union KUE

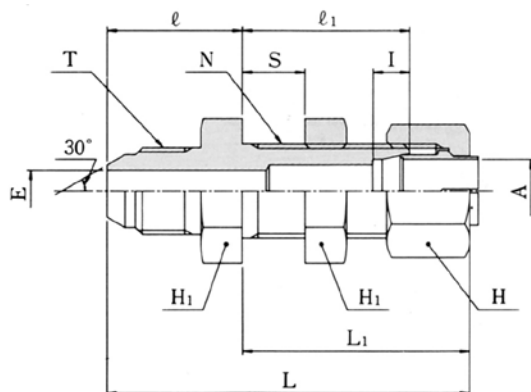

unit: mm

Part No.	Tube OD A	(G) T	Minimum Opening E	Hex.		I	$\ell_1$	$\ell$	Approx. L <sub>1</sub>	Approx. L	N	Max. S	Weight (kg)
				H <sub>1</sub>	H								
KUE08-020CE	8	¼	5.5	17	14	5.5	27.5	22	37.5	59.5	M12×1	13	0.050
KUE08-030CE	8	⅜	6	17	14	5.5	27.5	24	37.5	61.5	M12×1	13	0.059
KUE10-020CE	10	¼	5.5	19	17	5.5	29	23	39	62	M14×1	13	0.068
KUE10-030CE	10	⅜	8	19	17	5.5	29	25	39	64	M14×1	13	0.074
KUE12-020CE	12	¼	5.5	22	19	6	29	23.5	39	62.5	M16×1	13	0.095
KUE12-030CE	12	⅜	8	22	19	6	29	25	39	64	M16×1	13	0.089
KUE12-040CE	12	½	10	22	19	6	29	27	39	66	M16×1	13	0.101
KUE16-030CE	16	⅜	8	27	27	8	34	25.5	46.6	72.1	M22×1.5	15	0.170
KUE16-040CE	16	½	10	27	27	8	34	28	46.6	74.6	M22×1.5	15	0.177
KUE20-040CE	20	½	10	32	30	8	36	30.5	50.3	80.8	M26×1.5	15	0.220
KUE20-060CE	20	¾	16	32	30	8	36	32	50.3	82.3	M26×1.5	15	0.247
KUE25-060CE	25	¾	16	36	36	9	37.5	33	52.3	85.3	M32×1.5	15	0.332
KUE25-080CE	25	1	21.5	36	36	9	37.5	33.5	52.3	85.8	M32×1.5	15	0.337
KUE30-060CE	30	¾	16	41	41	9	39	33	54.3	87.3	M36×1.5	15	0.332
KUE30-080CE	30	1	21.5	41	41	9	39	34	54.3	88.3	M36×1.5	15	0.418

**⚠ CAUTION :** This type of fitting is designed to be used for wall penetration. When used in the place of strong vibration and/or pressure fluctuation, proper vibration measures such as fixing the piping by clamp are required.

# Male Seat Hose Connection Bulkhead Elbow KLH

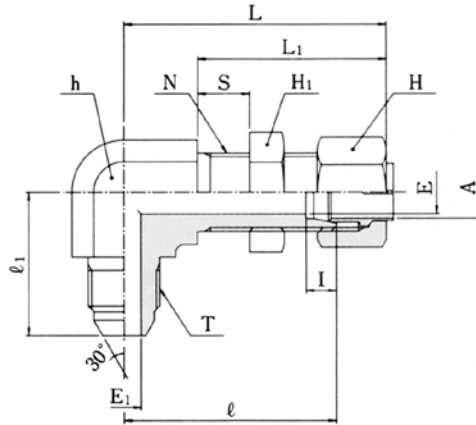

unit: mm

Part No.	Tube OD	(G) T	E	E <sub>1</sub>	Flats h	Hex.		I	l <sub>1</sub>	l	Approx. L <sub>1</sub>	Approx. L	N	Max. S	Weight (kg)
						H <sub>1</sub>	H								
KLH08-020CE	8	¼	6	5.5	19	17	14	5.5	28	45	37.5	55	M12×1	13	0.101
KLH08-030CE	8	⅜	6	8	19	17	14	5.5	30	45	37.5	55	M12×1	13	0.104
KLH10-020CE	10	¼	8	5.5	19	19	17	5.5	28	46.5	39	56.5	M14×1	13	0.109
KLH10-030CE	10	⅜	8	8	19	19	17	5.5	30	46.5	39	56.5	M14×1	13	0.113
KLH12-020CE	12	¼	10	5.5	22	22	19	6	30	47	39	57	M16×1	13	0.123
KLH12-030CE	12	⅜	10	8	22	22	19	6	31	47	39	57	M16×1	13	0.150
KLH12-040CE	12	½	10	10	24	22	19	6	35	49	39	59	M16×1	13	0.189
KLH16-030CE	16	⅜	13	8	27	27	27	8	34	56	46.6	68.6	M22×1.5	15	0.275
KLH16-040CE	16	½	13	10	27	27	27	8	36	56	46.6	68.6	M22×1.5	15	0.282
KLH20-040CE	20	½	17	10	32	32	30	8	38	64	50.3	78.3	M26×1.5	15	0.409
KLH20-060CE	20	¾	17	16	32	32	30	8	40	64	50.3	78.3	M26×1.5	15	0.410
KLH25-060CE	25	¾	22	16	41	36	36	9	42	67	52.3	81.8	M32×1.5	15	0.659
KLH25-080CE	25	1	22	21.5	41	36	36	9	43	67	52.3	81.8	M32×1.5	15	0.690
KLH30-060CE	30	¾	26	16	41	41	41	9	42	70	54.3	85.3	M36×1.5	15	0.610
KLH30-080CE	30	1¼	26	21.5	41	41	41	9	43	70	54.3	85.3	M36×1.5	15	0.758

**⚠ CAUTION :** This type of fitting is designed to be used for wall penetration. When used in the place of strong vibration and/or pressure fluctuation, proper vibration measures such as fixing the piping by clamp are required.

# Female Seat Hose Connection Union KUD

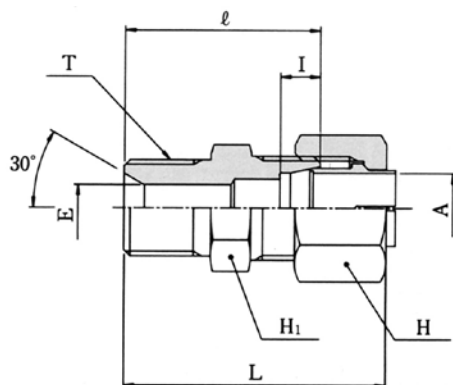

unit: mm

Part No.	Tube OD A	(G) T	Minimum Opening E	Hex.		l	$\ell$	Approx. L	Weight (kg)
				H <sub>1</sub>	H				
KUD08-020CE	8	¼	5.5	14	14	5.5	26.5	36.5	0.029
KUD08-030CE	8	⅜	6	17	14	5.5	29.5	39.5	0.038
KUD10-020CE	10	¼	5.5	14	17	5.5	27	37	0.033
KUD10-030CE	10	⅜	8	17	17	5.5	30	40	0.043
KUD12-020CE	12	¼	5.5	17	19	6	28	38	0.040
KUD12-030CE	12	⅜	8	17	19	6	30	40	0.046
KUD12-040CE	12	½	10	22	19	6	34.5	44.5	0.071
KUD16-030CE	16	⅜	8	22	27	8	33.5	46.1	0.093
KUD16-040CE	16	½	10	22	27	8	36.5	49.1	0.105
KUD20-040CE	20	½	10	27	30	8	36.5	50.8	0.126
KUD20-060CE	20	¾	16	27	30	8	38.5	52.8	0.131
KUD25-060CE	25	¾	16	32	36	9	41.5	56.3	0.183
KUD25-080CE	25	1	21.5	36	36	9	44.5	59.3	0.226
KUD30-060CE	30	¾	16	36	41	9	43	58.3	0.238
KUD30-080CE	30	1	21.5	36	41	9	45	60.3	0.256

# Female Seat Hose Connection Union Elbow KLE

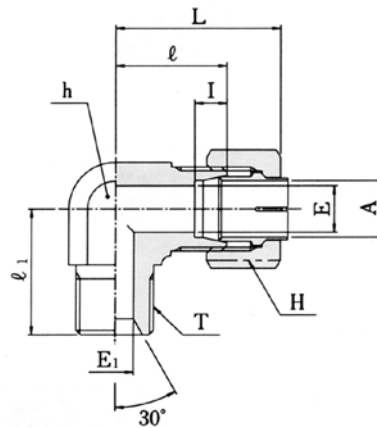

unit: mm

Part No.	Tube OD A	(G) T	E	E <sub>1</sub>	Flats h	Hex. H	I	l <sub>1</sub>	l	Approx. L	Weight (kg)
KLE08-020CE	8	¼	6	5.5	14	14	5.5	24	17.5	27.5	0.042
KLE08-030CE	8	⅜	6	8	17	14	5.5	26.5	20.5	30.5	0.063
KLE10-020CE	10	¼	8	5.5	14	17	5.5	24	20	30	0.048
KLE10-030CE	10	⅜	8	8	17	17	5.5	26.5	21	31	0.067
KLE12-020CE	12	¼	10	5.5	17	19	6	25	21	31	0.067
KLE12-030CE	12	⅜	10	8	17	19	6	26.5	21	31	0.073
KLE12-040CE	12	½	10	10	24	19	6	33	24	34	0.141
KLE16-030CE	16	⅜	13	8	24	27	8	30	28	40.6	0.164
KLE16-040CE	16	½	13	10	24	27	8	33	28	40.6	0.179
KLE20-040CE	20	½	17	10	27	30	8	35	30.5	44.8	0.174
KLE20-060CE	20	¾	17	16	30	30	8	38	30.5	44.8	0.267
KLE25-060CE	25	¾	22	16	36	36	9	41	35.5	50.3	0.407
KLE25-080CE	25	1	22	21.5	36	36	9	43	35.5	50.3	0.413
KLE30-060CE	30	¾	26	16	41	41	9	44	39.5	54.8	0.550
KLE30-080CE	30	1	26	21.5	41	41	9	46	39.5	54.8	0.570

## Female Seat Hose Connection Bulkhead Union KUF

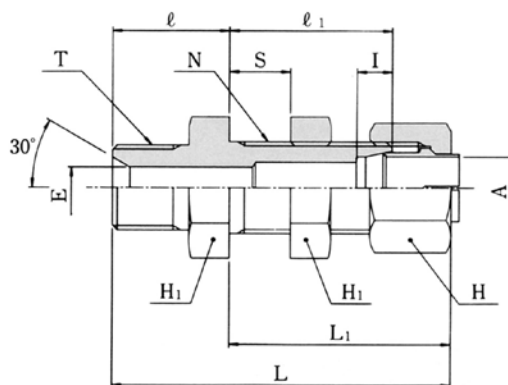

unit: mm

Part No.	Tube OD A	(G) T	Minimum Opening E	Hex.		I	$\ell_1$	$\ell$	Approx. L <sub>1</sub>	Approx. L	N	Max. S	Weight (kg)
				H <sub>1</sub>	H								
KUF08-020CE	8	¼	5.5	17	14	5.5	27.5	19	37.5	56.5	M12×1	13	0.051
KUF08-030CE	8	⅜	6	17	14	5.5	27.5	21	37.5	58.5	M12×1	13	0.059
KUF10-020CE	10	¼	5.5	19	17	5.5	29	20	39	59	M14×1	13	0.067
KUF10-030CE	10	⅜	8	19	17	5.5	29	22	39	61	M14×1	13	0.073
KUF12-020CE	12	¼	5.5	22	19	6	29	20	39	59	M16×1	13	0.093
KUF12-030CE	12	⅜	8	22	19	6	29	22	39	61	M16×1	13	0.094
KUF12-040CE	12	½	10	22	19	6	29	25	39	64	M16×1	13	0.102
KUF16-030CE	16	⅜	8	27	27	8	34	23	46.6	69.6	M22×1.5	15	0.185
KUF16-040CE	16	½	10	27	27	8	34	26	46.6	72.6	M22×1.5	15	0.180
KUF20-040CE	20	½	10	32	30	8	36	28	50.3	78.3	M26×1.5	15	0.240
KUF20-060CE	20	¾	16	32	30	8	36	30	50.3	80.3	M26×1.5	15	0.241
KUF25-060CE	25	¾	16	36	36	9	37.5	31	52.3	83.3	M32×1.5	15	0.328
KUF25-080CE	25	1	21.5	36	36	9	37.5	33	52.3	85.3	M32×1.5	15	0.338
KUF30-060CE	30	¾	16	41	41	9	39	31.5	54.3	85.8	M36×1.5	15	0.425
KUF30-080CE	30	1	21.5	41	41	9	39	33.5	54.3	87.8	M36×1.5	15	0.428

**CAUTION** : This type of fitting is designed to be used for wall penetration. When used in the place of strong vibration and/or pressure fluctuation, proper vibration measures such as fixing the piping by clamp are required.

# Adapter KHA

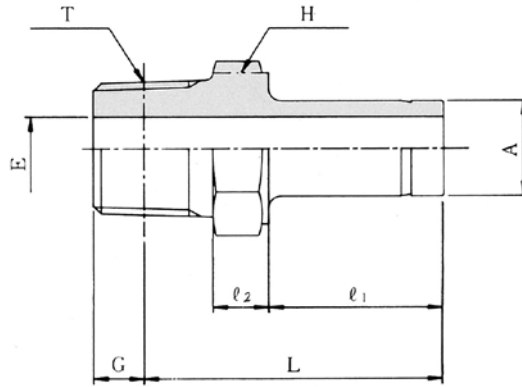

unit: mm

Part No.	Tube OD A	(R) T	Minimum Opening E	Gauge Length G	Hex. H	$l_1$	$l_2$	Approx. L	Weight (kg)
KHA06-010CE	6	1/8	3	3.97	10	19	5	30	0.011
KHA06-020CE	6	1/4	3	6.01	14	19	7	34	0.024
KHA08-010CE	8	1/8	4	3.97	10	19	5	30	0.013
KHA08-020CE	8	1/4	5	6.01	14	19	7	34	0.025
KHA10-020CE	10	1/4	6	6.01	14	19	7	34	0.026
KHA10-030CE	10	3/8	6	6.35	17	19	7	34.6	0.039
KHA12-020CE	12	1/4	8	6.01	14	20	7	35	0.026
KHA12-030CE	12	3/8	8	6.35	17	20	7	35.7	0.039
KHA16-030CE	16	3/8	9	6.35	17	24	7	39.7	0.044
KHA16-040CE	16	1/2	11	8.16	22	24	8	42.8	0.070
KHA20-040CE	20	1/2	12	8.16	22	26	8	44.8	0.090
KHA20-060CE	20	3/4	14	9.53	27	26	10	47.5	0.128
KHA25-060CE	25	3/4	16	9.53	27	28	10	49.5	0.133
KHA25-080CE	25	1	18	10.39	36	28	11	52.6	0.221
KHA30-060CE	30	3/4	16	9.53	32	28	10.5	50	0.218
KHA30-080CE	30	1	22	10.39	36	28	11	52.6	0.221
KHA30-100CE	30	3/4	22	12.7	46	28	12	54.3	0.420

# Adjustable Elbow KLC

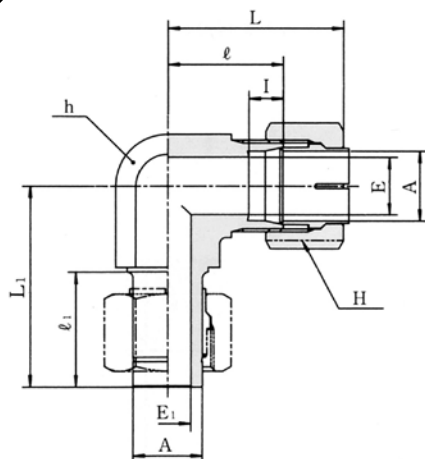

unit: mm

Part No.	Tube OD A	E	E <sub>1</sub>	Flats h	Hex. H	I	l	l <sub>1</sub>	Approx. L	L <sub>1</sub>	Weight (kg)
KLC10-000CE	10	8	6	17	17	5.5	20	19	30	34	0.054
KLC12-000CE	12	10	8	17	19	6	20	20	30	35	0.063
KLC16-000CE	16	13	11	27	27	8	30	24	42.6	43	0.259
KLC20-000CE	20	17	14	30	30	8	31	26	45.3	43	0.255
KLC25-000CE	25	22	18	36	36	9	34.5	28	49.3	49	0.472
KLC30-000CE	30	26	22	41	41	9	38	28	53.3	53	0.509

# Reducer KRE

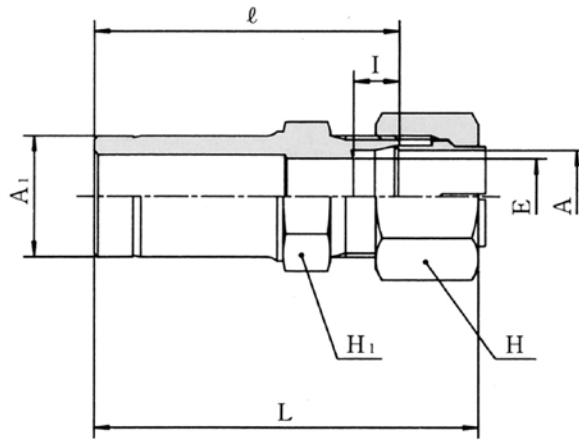

unit: mm

Part No.	A <sub>1</sub>	Tube OD A	Minimum Opening E	Hex.		l	ℓ	Approx. L	Weight (kg)
				H <sub>1</sub>	H				
KRE08×060CE	8	6	4.5	10	12	5.5	32	41.3	0.020
KRE10×060CE	10	6	4.5	12	12	5.5	33	42.3	0.028
KRE10×080CE	10	8	6	12	14	5.5	33.5	43.5	0.029
KRE12×060CE	12	6	4.5	14	12	5.5	35	44.3	0.036
KRE12×080CE	12	8	6	14	14	5.5	35.5	45.5	0.037
KRE12×100CE	12	10	8	14	17	5.5	36	46	0.037
KRE16×060CE	16	6	4.5	17	12	5.5	39	48.3	0.078
KRE16×080CE	16	8	6	17	14	5.5	39.5	49.5	0.079
KRE16×100CE	16	10	8	17	17	5.5	40	50	0.078
KRE16×120CE	16	12	10	17	19	6	40	50	0.078
KRE20×060CE	20	6	4.5	22	12	5.5	42	51.3	0.107
KRE20×080CE	20	8	6	22	14	5.5	42.5	52.5	0.109
KRE20×100CE	20	10	8	22	17	5.5	43	53	0.109
KRE20×120CE	20	12	10	22	19	6	43	53	0.109
KRE20×160CE	20	16	13	22	27	8	45	57.6	0.112
KRE25×160CE	25	16	13	27	27	8	49	61.6	0.171
KRE25×200CE	25	20	17	27	30	8	49	63.3	0.154
KRE30×200CE	30	20	17	32	30	8	49	63.3	0.232
KRE30×250CE	30	25	22	32	36	9	49.5	64	0.344

## Plug KBA

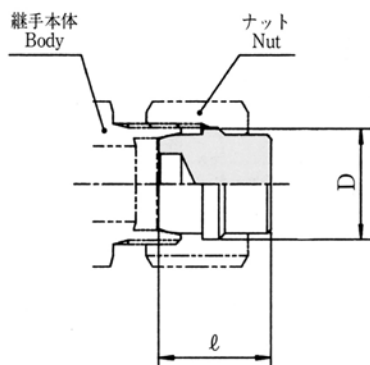

unit: mm

Part No.	Tube OD A	D	ℓ	Weight (kg)
KBA06-000CE	6	8.7	13.7	0.005
KBA08-000CE	8	10.7	14.5	0.008
KBA10-000CE	10	12.7	14.8	0.013
KBA12-000CE	12	14.7	14.9	0.033
KBA16-000CE	16	20	18.2	0.036
KBA20-000CE	20	24	20.1	0.053
KBA25-000CE	25	29.3	21.2	0.098
KBA30-000CE	30	34	21.6	0.141

## Nut KKN

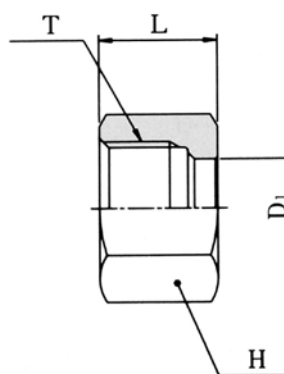

unit: mm

Part No.	Tube OD A	D <sub>1</sub>	T	Hex. H	L	Weight (kg)
KKN06-000CE	6	7.05	M10×1	12	12	00
KKN08-000CE	8	9.05	M12×1	14	13	00
KKN10-000CE	10	11.15	M14×1	17	13.5	00
KKN12-000CE	12	13.15	M16×1	19	13.5	00
KKN16-000CE	16	17.35	M22×1.5	27	17	00
KKN20-000CE	20	21.75	M26×1.5	30	19	00
KKN25-000CE	25	26.75	M32×1.5	36	20	00
KKN30-000CE	30	31.85	M36×1.5	41	21	00

## Sleeve KKO

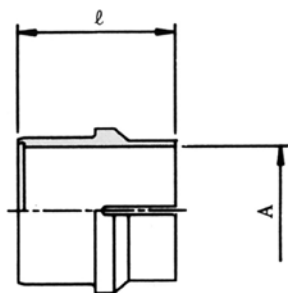

unit: mm

Part No.	Tube OD A	ℓ	Weight (kg)
KKO06-000CE	6	11.5	00
KKO08-000CE	8	12	00
KKO10-000CE	10	12	00
KKO12-000CE	12	12	00
KKO16-000CE	16	15.5	00
KKO20-000CE	20	17	00
KKO25-000CE	25	17.5	00
KKO30-000CE	30	18	00

## Presetting Tool PJA

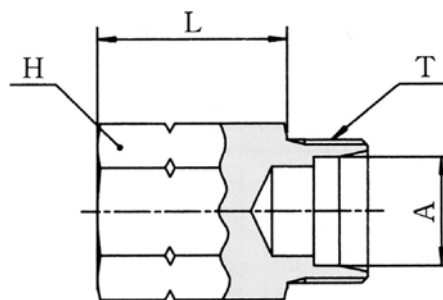

unit: mm

Part No.	Tube OD A	L	Hex. H	T	Weight (kg)
PJA06-000CE	6	40	17	M10×1	00
PJA08-000CE	8	40	17	M12×1	00
PJA10-000CE	10	40	17	M14×1	00
PJA12-000CE	12	40	17	M16×1	00
PJA16-000CE	16	40	27	M22×1.5	00
PJA20-000CE	20	40	27	M26×1.5	00
PJA25-000CE	25	40	41	M32×1.5	00
PJA30-000CE	30	40	41	M36×1.5	00

# Union KZU

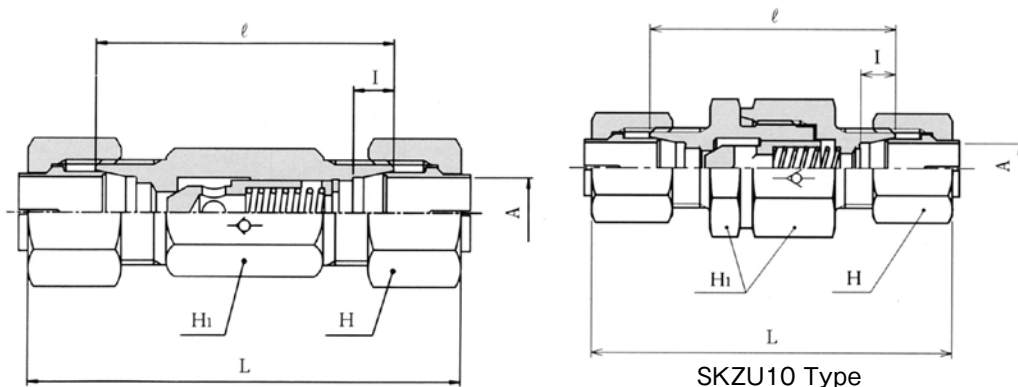

unit: mm

Part No.	Out. Dia. of Applied Pipe A		Flow rate $\ell$ / min	Cracking Pressure MPa	Hex.		I	$\ell$	Fingertight Approx. L	Weight (kg)
	Nominal sizes	Out. Dia.			H <sub>1</sub>	H				
SKZU10-050CE	10		18	0.05	24	17	5.5	49	69	0.125
SKZU10-450CE	10		18	0.45	24	17	5.5	49	69	0.125
KZU12-050CE	12		18	0.05	19	19	6	51	71	0.100
KZU12-450CE	12		18	0.45	19	19	6	51	71	0.100
KZU16-050CE	16		35	0.05	27	27	8	58	83	0.252
KZU16-450CE	16		35	0.45	27	27	8	58	83	0.252
KZU20-050CE	20		60	0.05	30	30	8	66	94.5	0.360
KZU20-450CE	20		60	0.45	30	30	8	66	94.5	0.360
KZU25-050CE	25		95	0.05	36	36	9	78	107.5	0.510
KZU25-450CE	25		95	0.45	36	36	9	78	107.5	0.510
KZU30-050CE	30		140	0.05	41	41	9	89	119.5	0.904
KZU30-450CE	30		140	0.45	41	41	9	89	119.5	0.904

⚠ CAUTION : Please inquire us when the fitting will be used excepting hydraulic oil.

## Specifications

Rated pressure  $\phi$  10~30: 14MPa (140kgf/cm<sup>2</sup>)

Fluid Hydraulic Oil

Working temperature -20~150°C

Flow rate refer to table on right

Pressure Loss Pressure loss Vs. flow rate under oil viscosity of 125 SSU (26cSt) is shown in right figure.

Cracking Pressure The cracking pressure of 0.05MPa (0.5kgf/cm<sup>2</sup>) and 0.45MPa (4.5kgf/cm<sup>2</sup>) are available.

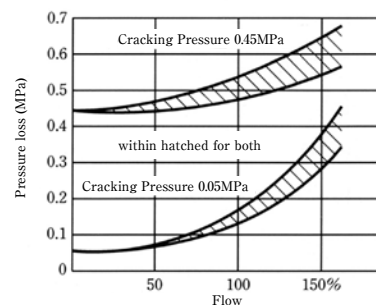

# Check Connector KZC

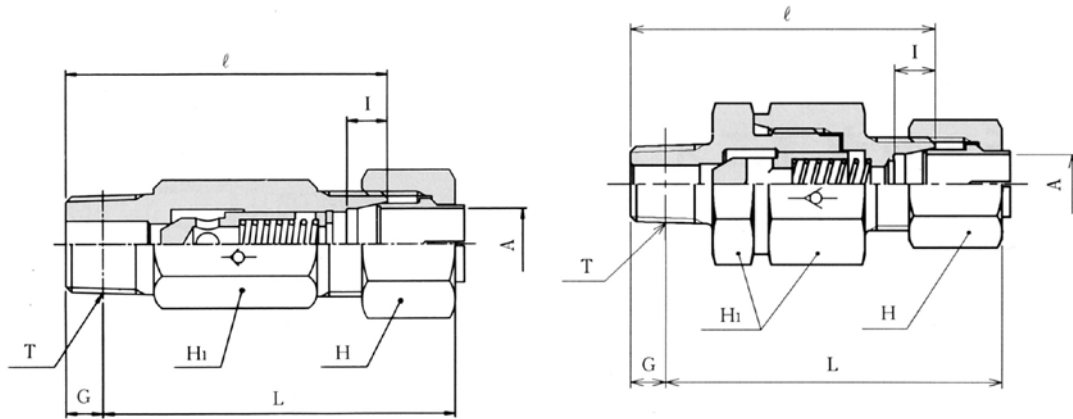

unit: mm

Part No.	Out. Dia. of Applied Pipe A		Flow rate $l/min$	Cracking Pressure MPa	Hex.		l	$\ell$	Fingertight Approx. L	Weight (kg)
	Nominal sizes	Out. Dia.			H <sub>1</sub>	H				
SKZC10-050CE	10		18	0.05	24	17	5.5	53	63	0.120
SKZC10-450CE	10		18	0.45	24	17	5.5	53	63	0.120
KZC12-050CE	12		18	0.05	19	19	6	55	58.5	0.096
KZC12-450CE	12		18	0.45	19	19	6	55	58.5	0.096
KZC16-050CE	16		35	0.05	27	27	8	65	69.5	0.221
KZC16-450CE	16		35	0.45	27	27	8	65	69.5	0.221
KZC20-050CE	20		60	0.05	30	30	8	75	80	0.331
KZC20-450CE	20		60	0.45	30	30	8	75	80	0.331
KZC25-050CE	25		95	0.05	36	36	9	87	91.5	0.515
KZC25-450CE	25		95	0.45	36	36	9	87	91.5	0.515
KZC30-050CE	30		140	0.05	41	41	9	100	102.5	0.927
KZC30-450CE	30		140	0.45	41	41	9	100	102.5	0.927

**CAUTION** : Please inquire us when the fitting will be used excepting hydraulic oil.

## Specifications

- Rated pressure  $\phi 10\sim 30: 14\text{MPa} (140\text{kgf/cm}^2)$
- Fluid Hydraulic Oil
- Working temperature  $-20\sim 150^\circ\text{C}$
- Flow rate refer to table on right
- Pressure Loss Pressure loss Vs. flow rate under oil viscosity of 125 SSU (26cSt) is shown in right figure.
- Cracking Pressure The cracking pressure of 0.05MPa (0.5kgf/cm<sup>2</sup>) and 0.45MPa (4.5kgf/cm<sup>2</sup>) are available.

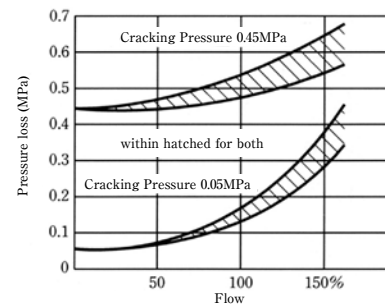



## Hand operating Pre-setting Device

When tightening the same size of fittings in many, using the device makes the presetting work very efficiently and provides uniform work performance.

Manual and hydraulic operated are available. For manual type, there are two types. Type PSD-S is used for  $\phi 6 \sim \phi 20$ , and type PSD-BCE is used for  $\phi 25 / \phi 30$ . For presetting work, another parts which are sold separately are required.

Please select the proper jigs and sleeve receiver corresponding to the size from the table below.

### PSD-S( $\phi 6 \sim \phi 20$ )

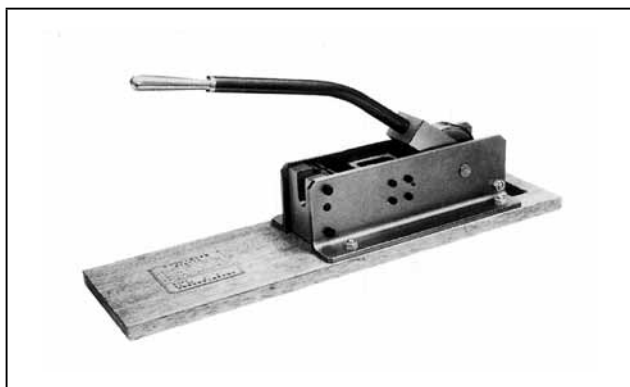

Tube OD	Clamping Jig	Sleeve Holder
6	PJS06-00CE	PJU06-00SE
8	PJS08-00CE	PJU08-00SE
10	PJS10-00CE	PJU10-00SE
12	PJS12-00CE	PJU12-00SE
16	PJS16-00CE	PJU16-00SE
20	PJS20-00CE	PJU20-00SE

### PSD-BCE( $\phi 25, \phi 30$ )



Tube OD	Clamping Jig	Sleeve Holder
25	PJB25-00CE	PJU25-BCE
30	PJB30-00CE	PJU30-BCE

### CAUTION

1. Cut the tube aiming at obtaining cutting angle of  $90^\circ \pm 1^\circ$ . Remove the burrs from outside and inside of the cut tube edge. Exercise not to scratch the surface more than 0.1mm depth.
2. Keep more than 80mm straight length from the tube end.
3. Properly lubricate on the movable parts.
4. Tightening jig and sleeve receiver are consumable parts. Replace them periodically correspond to the use frequency.
5. When tightening, make sure that the tube end bottoms in the jig. In case of the tube is very long, work by two men or prepare the support to keep the tube horizontally.
6. Do not modify the device or parts. Due to the cause of modification, there will be possibility of impairing the performance.

## Hydraulic Pre-setting Device

With this equipment preliminary tightening can be performed on the entire CE type fitting sizes. Even for 3-D bent pipe, only one worker can achieve the preset work using foot switch.

Applicable tube sizes: From 6 mm dia. To 30 mm dia.



**WARNING**

If you don't select and handle fittings, valves and related accessories in an adequate manner, it may damage human beings and applicable systems.  
Within the responsibility and authorization of users and piping designers, fittings, valves and related accessories shall be adequately selected, assembled, used and maintained based on the applicable conditions and product conformity to the system to be applied. Please read carefully our operation manual and feel free to contact with Ihara if you have any question or request.

---

## ***IHARA SCIENCE CORPORATION***

---

You can get more information at Home Page.

<http://www.ihara-sc.co.jp>

### **Headquarters/Sales Offices**

#### **Headquarters**

##### **East Japan Sales Office**

11-3 Takanawa 3-chome Minato-ku,  
Tokyo 108-0074 Japan  
TEL: +81-3-6721-6981 FAX: +81-3-6721-6991

##### **Tohoku Sales Office**

5600-3, Higashineko, Oaza, Higashine city,  
Yamagata prefecture 999-3701  
TEL: +81-237-43-7802 FAX: +81-237-43-7803

##### **Chubu Sales Office**

Tsukasa Building, 3-14-19, Chiyoda, Naka ward,  
Nagoya city, Aichi prefecture 460-0012  
TEL: +81-52-323-2627 FAX: +81-52-323-2630

##### **Kansai Sales Office**

7F, GL Osaka Building, 4-1-18, Tenma, Kita ward  
Osaka city, Osaka prefecture 530-0043  
TEL: +81-6-6358-9255 FAX: +81-6-6358-9260

##### **West Japan Sales Office**

1-17-20, Higashizuka, Kurashiki city,  
Okayama prefecture 712-8044  
TEL: +81-86-455-1811 FAX: +81-86-455-1822

##### **Kyushu Sales Office**

103, Maison de Sophie, 1-1-8, Onoue, Kumamoto  
city, Kumamoto prefecture 862-0913  
TEL: +81-96-386-5353 FAX: +81-96-386-5354

### **Group Companies**

#### **Yamagata-Ihara Corporation**

5600-3, Higashineko, Oaza, Higashine city,  
Yamagata prefecture 999-3701  
TEL: +81-237-43-5501 FAX: +81-237-43-5504

#### **IHARA SCIENCE TAIWAN Co.,Ltd**

No.79, Mingyi St., West Dist.,  
Taichung City 403, Taiwan (R.O.C.)  
TEL:+886-4-2319-1116 FAX:+886-4-2319-1126

#### **SUZHOU IHARA SCIENCE Co.,Ltd.**

SHANGHAI OFFICE  
UnitJ-11F,Huamin Empire Plaza,  
No.728, YanAn Road(W),  
Shanghai 200050,R.P.Chaina  
TEL:+86-21-5239-9884 FAX:+86-21-5283-3811

#### **IHARA KOREA Co.,Ltd**

Digital Empire II103-905, Sinwon-ro 88,  
Yeongtong-Gu, Suwon-Si  
Gyeonggi-Do, 443-734, South Korea  
TEL :+82-31-695-6800 FAX :+82-31-695-6808

#### **IHARA SCIENCE USA CORPORATION**

1915 Peters Road, Suite 103 Irving, Texas 75061  
TEL:+1-469-586-4671 FAX: +1-469-586-4723