

登録
26.03.09
技術部

Program No.
プログラム No.

Parts List No.
部品表 No.

TEST	BODY PRESSURE	6 bar
	SEAT LEAKAGE	6 bar
	GREASE FREE	CLASS 3

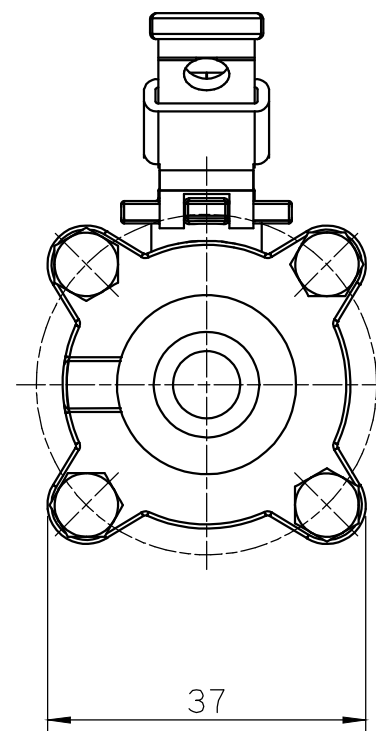
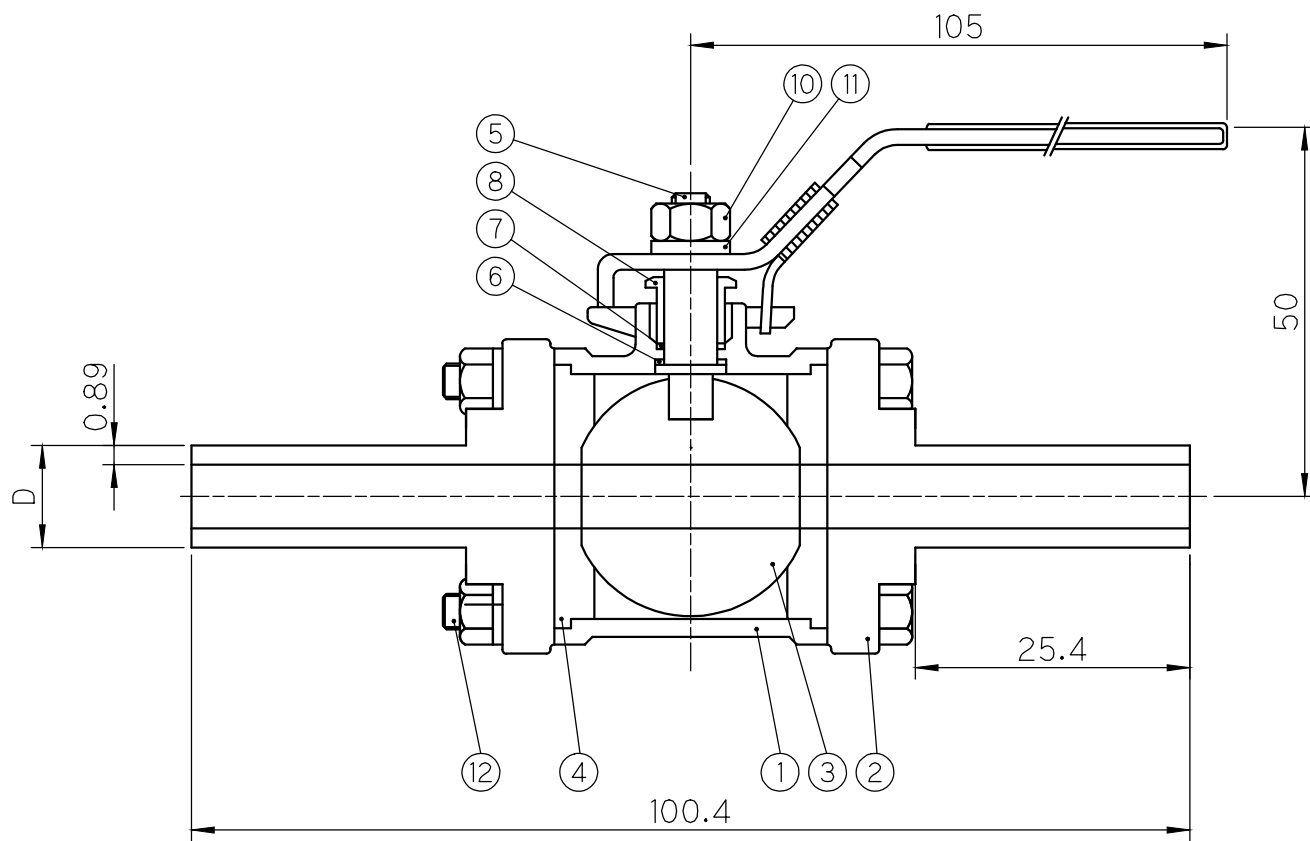
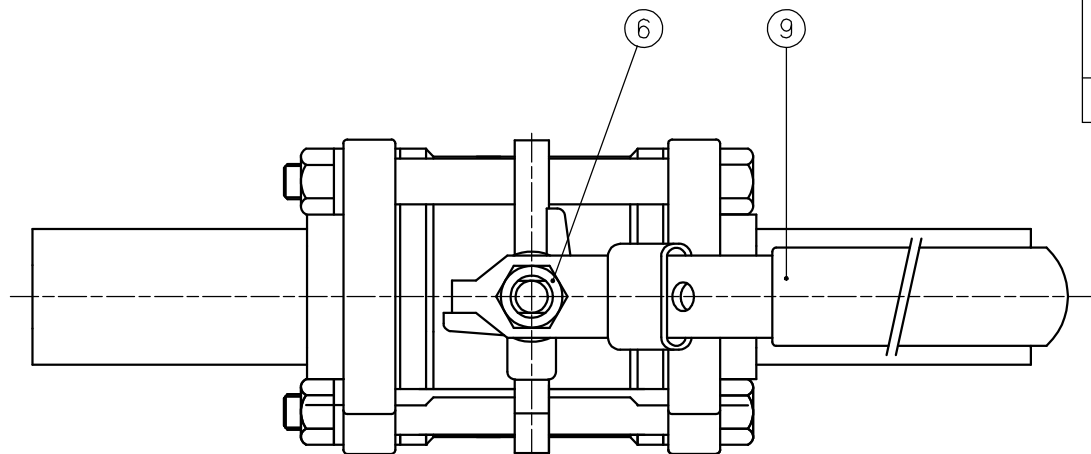

Type	Size	D	Ra xx(μinch)		Cv Values
			BA Grade	EP Grade	
TV3F-4TW0.89-EP/BA	1/4"	6.35	25	10	0.6
TV3F-6TW0.89-EP/BA	3/8"	9.53	25	10	2.9

No. 部番	Name of Part 部品名	Qty 数量	Material 材質	Drawing No. 図面番号
1	Body	1	A351-CF8M	
2	End Cap	2	A351-CF3M	
3	Ball	1	316 SS	
4	Seat	2	PTFE	
5	Stem	1	A276-316	
6	Stem Seal	1	PTFE	
7	Stem Packing	1	PTFE	
8	Gland Nut	1	304 SS	
9	Handle Set	1s	304 SS	
10	Handle Nut	1	304 SS	
11	Handle Washer	1	304 SS	
12	Bolt&Nut&Washer	1s	304 SS	
13				
14				
15				
16				
17				
18				
19				
20				
21				
22				
23				
24				
25				
26				
27				
28				
29				
30				

No. 変更番号	Revision contents 変更内容		Date 日付	Mdf.by 変更	Approved by 承認
	Design Pressure 設計圧力	Design Temperature 設計温度	Operating Pressure 操作圧力		
	1000psi				
	Material Size 素材寸法	Material 材質	Treatment 処理		
	Nom. Size 呼び寸法	Connection 接続	Series シリーズ		
	1/4"~3/8"	TW	TV3F		
Checked By	Approved By	Type 型式			
岸 2026年3月9日	岸 2026年3月9日		Title 名称		
			Ball Valve		
Designed By	Drawing By	Scale 尺度	Drawing No. 図番		
	六平 2026年3月9日 愛美	NTS 3rd Angle Projection 三角法	TV3F-TW-01 イハラサイエンス株式会社 IHARA SCIENCE CORPORATION		